



Table of contents

1 Foreword	6
1.1 Appropriate usage	6
2 General information	7
2.1 Explanation of the symbols in the manual	7
2.2 Safety information	7
2.2.1 Safety principles	7
2.2.2 General safety information	8
2.2.3 Transport safety information	8
2.2.4 Safety information for operator	8
2.2.5 Safety information for operating personnel	9
2.2.6 Operating safety	9
2.2.7 Safety information for maintenance, servicing and trouble shooting	10
2.2.8 Safety when working with electricity	10
2.3 Personal protection information	10
2.4 Warning information	11
2.5 Safety devices	12
2.6 Intended use	12
2.7 Function	12
3 Technical description	13
3.1 Technical data	13
3.2 Machine overview	16
4 Commissioning	17
4.1 Preparations for the transport of the machine	17
4.2 Transport	20
4.3 Installation	21
4.4 Connections and other preparations	23
4.4.1 Power supply	24
4.4.2 Coolant container	24
4.4.3 Ski centering with V-rollers	25
4.4.4 Adjust the centerings for alpine and cross country ski	26
5 Description of the operating elements	27
5.1 Operating panel	27
6 Loading - saving- deleting a grinding program	29
6.1 Loading grinding program	29
6.2 Saving the grinding program	30
6.2.1 Save as	30
6.3 Delete a grinding program	31
6.4 Lock and unlock a grinding program	31
6.5 Saving a grinding program on an USB-stick	31
6.6 Loading a grinding program from an USB stick	32

6.7 Program info	33
6.8 Information about the input fields	33
7 Changing a grinding program	34
7.1 Editing display	34
7.1.1 Structure layers	34
7.1.2 Loading a structure	34
7.1.3 Combined structures over the stone width	35
7.1.4 Changing the structure width	35
7.1.5 Changing structure parameters	36
7.1.5.1 Standard parameters	37
7.1.5.2 Parameters crossed structure	38
7.1.5.3 Parameters wave structure	38
7.1.5.4 Parameters linear structure	39
7.1.5.5 Parameters real linear structure	39
7.1.5.6 Structure info	39
7.1.5.7 Deleting a structure	40
7.1.5.8 Saving a structure in the user pool	40
7.1.5.9 Copying and linking structures	41
7.1.6 Grinding parameters	42
7.1.7 Variable grinding parameters	42
7.1.8 Facing parameters	44
7.1.9 Layer offset	44
7.1.10 Removing structures	45
7.2 Process display	45
7.2.1 Change grinding values	47
8 Working with the machine	48
9 General settings	50
9.1 User settings	50
9.2 Stone- / diamond changing assistant	51
9.3 Display / Info / IP-Host	52
9.3.1 Change date/time	52
9.3.2 Change brightness	52
9.3.3 Select the language	52
9.3.4 Calibrate touch	52
9.4 Times and counters	53
9.5 Balancing mode	53
9.6 Grind-in mode	53
9.7 Current alarms	54
9.8 Alarmhistory	54
9.9 Alarm overview	54
9.10 Neutral position	55
10 Malfunctions	56
10.1 Alarm messages on the display	56
10.2 Mechanical malfunctions	56
11 Maintenance	58

11.1 Maintenance table	58
11.1.1 Maintenance after end of season	59
11.1.2 Cleaning the machine with the cleaning hose	59
11.1.3 Cleaning the laser	60
11.1.4 Cleaning the filter cartridge	60
11.2 Stone- /diamond changing with the assistant	61
11.2.1 Changing the dressing diamond	62
11.2.2 Adding - modifying - deleting a diamond	63
11.2.3 Changing the grinding stone	64
11.2.4 Add grinding stone	66
11.2.5 Touching the diamond to the grinding stone	67
11.2.6 Facing the grinding stone	67
11.2.7 Balancing the grinding stone	68
11.2.8 Carry out test run according to official regulations	70
11.3 Changing the stone cleaning block	70
11.4 Changing the battery on the operating terminal	70
11.5 General information for the correct handling of solid cooling lubricants	71
12 Shut-down and disposal	73
Notes	74
13 Declaration of conformity	75

1 Foreword

These operating instructions must be read by the operators and by the persons responsible for the machine maintenance before initial use and serves as a supplement to the training documentation.

Damage caused by failure to follow the instructions herein will not be covered by the warranty. The user of this machine is legally bound to the casualty regulations of the country in question.

In addition, these operating instructions are confidential. It must only be accessible to authorized persons. Making it available to third parties requires the written approval of WINTERSTEIGER.

All documents are protected in accordance with copyright protection. The transfer and copying of these documents, even excerpts, and the utilization and communication of its content are not permitted, except if this was explicitly authorized in writing.

Noncompliance is punishable and establishes a compensation claim. All rights for the execution of commercial property rights are reserved by WINTERSTEIGER.

1.1 Appropriate usage

This machine was manufactured exclusively for grinding the base of alpine ski, carving ski, cross-country ski and ski-jumping ski (appropriate usage). Any other use is considered inappropriate. The manufacturer is not liable for any damage resulting from inappropriate use. The user takes full responsibility in such cases.

Appropriate usage includes following the operating, maintenance and repair provisions set out by the manufacturer. Any applicable accident prevention specifications and other generally accepted safety and medical regulations are also to be obeyed.

Any changes to the machine by the user renders manufacturer liability null and void with regards to any resulting damages.

We constantly try to improve our products and therefore reserve the right to make any changes or improvements we feel are appropriate. We are, however, not obligated to extend these changes or improvements to already delivered machines or devices.

All images, dimensions and weight specifications in the operating instructions are non-binding.

Translation of original operating manual

© Copyright 2009 by



WINTERSTEIGER

WINTERSTEIGER AG :: A-4910 Ried/Im Dimmelstrasse 9

Tel. +43 7752 919-0

e-mail: office@wintersteiger.at

Author and graphics: Franz Badegruber

Layout: Maria Marek-Pollhammer

2 General information

2.1 Explanation of the symbols in the manual



DANGER describes a danger with a high degree of risk, which will result in death or severe injury if it is not prevented.



WARNING describes a danger with a medium degree of risk, which could result in death or a severe injury if it is not prevented.



CAUTION describes a danger with a low degree of risk, which could result in small or moderate injury if it is not prevented.



This exclamation point refers to a possible damage or destruction of the product, the process and/or its environment.



Special information for the practical work or general recommendations can be found here.

These operating instructions are part of the machine. This is why suppliers of new and used machines are required to document in writing that these operating instructions were delivered with the machine. These operating instructions simplify the familiarization and work at the machine for the user.

The chapter servicing - maintenance includes tips on how you can keep the machine functional for many years. In addition, this machine provides information about (potential) dangers.

2.2 Safety information

2.2.1 Safety principles

- This machine is constructed using the best possible technology according to accepted safety regulations. However, dangers for the user or third parties as well as damages to the machine and other objects can occur if:
 - the device is used by untrained or unauthorized personnel
 - the device is used for inappropriate purposes,
 - the device is not properly maintained or repaired.

2.2.2 General safety information

- For the connection of the device to the electricity network, please assign an expert electrician, who knows the regulations of the domestic electricity utilities well and who applies them carefully.
- Observe connection voltage! The connection values are available on the name plate underneath the main switch. Check whether these specifications match the network voltage.
- The machine may only be operated with original WINTERSTEIGER spare parts or consumables. Any use of foreign material shall be at the risk of the operator and will invalidate the machine warranty.
- Good ventilation and exhaust must be provided due to the high humidity, which is generated by the grinding process!

2.2.3 Transport safety information

- Please wear a hard hat, safety shoes and protective gloves during transport work!
- Do not step underneath floating loads!
- Use only suitable, standardized and tested lifting equipment (fork lifts, truck-mounted cranes, hall bridge cranes) and lifting accessories (round slings, lifting straps, lifting ropes, chains) for the transport to the installation location.
- Always observe the maximum lifting loads when selecting the lifting equipment and the lifting accessories!
- Dimensions and weights can be found in the technical data.
- Ensure that the machine is transported free of shocks and knocks.
- Please observe the symbols on the packing.
- Please notify the supplier immediately about transport damages and/or missing parts.
- Always transport control cabinets upright!
- Connect transport boxes and transport cradles only at the identified connection points!
- Always secure transport loads against drops and overturns!
- Remove the transport safeguards only after installation!

2.2.4 Safety information for operator

- In addition to the binding regulations for accident prevention and occupational protection in effect in the country of use and at the site of deployment, please also be aware of the applicable professional rules for safety and technically appropriate operation.
- The operating company must ensure that the operators wear personal protective equipment.
- First-aid equipment (first-aid kit, etc.) should always be within reach! Make information about the location and the operation of fire extinguishing equipment available. Fire alarms and fire fighting options must be available.
- The operator/user of the machine may not make any changes or modifications to the machine that may affect safety without the authorization of WINTERSTEIGER.
- Only use trained or authorized personnel. Establish clear personnel responsibilities for operation, set-up, maintenance and repair! Assign the responsibility for the machine and the personnel to a machine operator. Persons who get trained, educated or introduced or who are in general apprenticeships can only work at the machine under constant supervision of an experienced operator!

2.2.5 Safety information for operating personnel

- Always have the operating instructions within reach at the machine location!
- Any applicable accident prevention specifications and other generally accepted safety and medical regulations are to be obeyed.
- The machine is only to be used if it is in technically sound condition and used safely for its intended purpose after having read these operating instructions! Faults that may affect safety must be immediately repaired!
- The operator is obligated to wear personal protective equipment!
- Please observe the switch-on and switch-off processes as well as the emergency switch-off during all activities that affect the operation, retooling and the settings of the machine and its safety equipment!
- Please observe the mandatory safety measures for inspection, maintenance and repair of the machine!

2.2.6 Operating safety

- The machine must only be operated by trained persons.
- The machine must only be commissioned if it is assembled and ready for operation.
- The machine must only be operated if all protection devices ([see chapt. 2.5 Safety devices, page 12](#)) and the safety related equipment, such as detachable safeguards and covers, are available and are functioning!
- The set-up operation must only be performed by qualified personnel. Unintentional movements can potentially be initiated by the work on limit switches and machine parts and these can result in severe injuries.
- Check at least once during each shift whether the machine has external damage or defects! Please report any changes (including changes to the operation) to the appropriate contact person! Switch the machine immediately off and secure it!
- Never leave the machine unattended during operation!
- Please observe the switch-on and switch-off processes, control displays in accordance with the operating instructions!
- The operators must switch the machine always off and secure it against switching on by unauthorized personnel if they leave the machine.
- Always unplug the mains plug before each location change or machine intervention!
- Do not operate the machine near flammable materials!
- Please wear appropriate work clothes:
 - long sleeve outerwear
 - long pants
 - protective gloves made from suitable material
 - protective goggles
- Do not touch rotating parts during operation!
- Do not reach into equipment that runs down, e.g. by pressing the emergency stop button!
- Do not reach with your hands during operation into the charging unit and do not store objects in this area.
- Two emergency stop buttons are used for switch off during emergencies. They are located on the operating panel of the machine and above the input pan of the machine.

2.2.7 Safety information for maintenance, servicing and trouble shooting

- Please adhere to the mandatory periods or periods listed in the operating instructions for recurring tests/inspections.
- All maintenance and servicing activities are only permitted if the main switch is switched off. Manual contacts with the running machines are banned! They can result in serious accidents. The machine must only be switched on while these activities take place during permissible operating modes and by adhering to special safety measures.
- Ensure safe and environmentally sound disposal of operating and auxiliary materials as well as spare parts.

2.2.8 Safety when working with electricity

- Switch the machine immediately off with the main switch if the electrical system of the machine malfunctions!
- Only qualified electricians working in accordance with the electrical rules can perform work at the electrical equipment of the machine! Make sure only qualified electricians have access to the electrical parts of the machine and are allowed to complete work at those parts. The control cabinets must always be locked as soon as they are not supervised.
- Only original fuses with the specified current ratings must be used! Never repair or bridge defect fuses. Replace fuses only by fuses of the same type.
- Changes to the control program can interfere with a safe operation. Program changes require a mandatory approval by the manufacturer.
- The flawless grounding of the electrical system must be guaranteed by a grounding conductor system.

2.3 Personal protection information



Wear goggles!

Order number: 78-150-095



Wear gloves!

Order number: 78-150-678



Wear protective equipment: close-fitting protective clothing

2.4 Warning information



Regular checks must be made to ensure that the warning labels are still attached to the machine. Illegible or missing warning labels must be replaced immediately.



The operating manual and the safety information must be read and observed before commissioning the machine.

Order number: 78-166-001

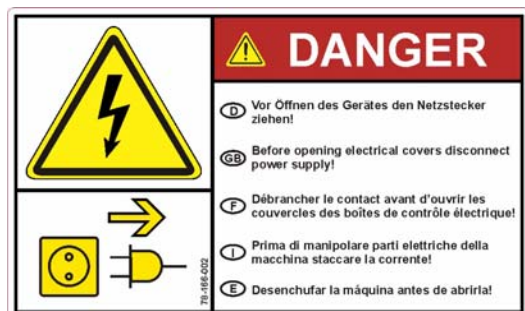

Remove the main plug before opening the device.

Order number: 78-166-002



The machine must be supervised while in use.

Order number: 78-166-020



Risk of injury!

Order number: 78-166-007

2.5 Safety devices

The following safety devices must not be removed or opened during grinding operation:

- [1] main protective sheet
- [2] stone coverage
- [3] covers at the top
- [4] Electrical system covers

as well as all other guards and covers, which guarantee a safe and injury free operation!

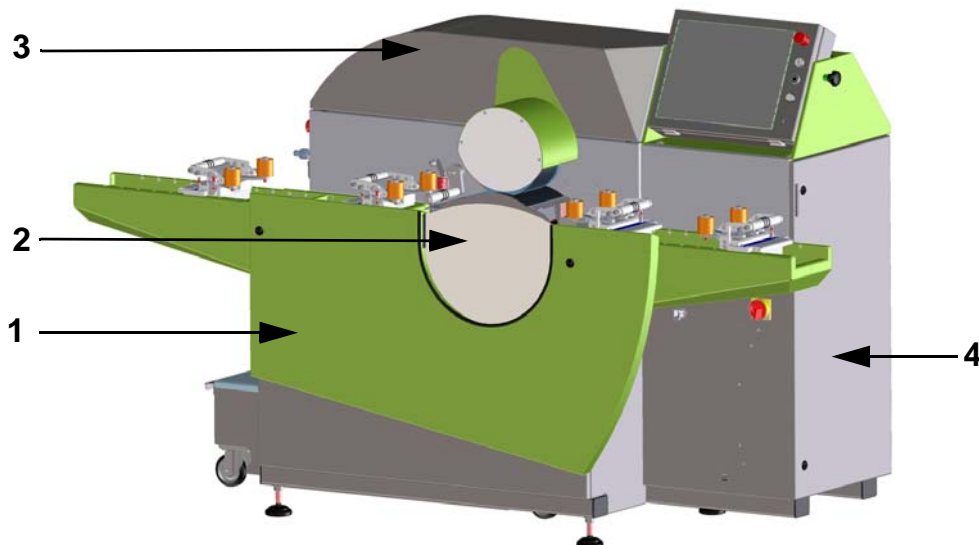

2.6 Intended use

The machine may only be used for grinding the base of alpine ski, carving ski, cross-country ski and ski-jumping ski.



If these instructions are not obeyed, WINTERSTEIGER is freed of any and all liability for damage incurred.

2.7 Function

The WINTERSTEIGER Race NC is a CNC single stone grinding machine for grinding and structuring the base for racing.

The machine is controlled by a touch screen display.

The Race NC is the unbeatable pioneer in the service of racing ski because of the total reproducing of structures, highest precision and an unimpeachable number of structures.

For skis with bindings it is necessary to fix the ski stops in the upward position and to provide the ski with a balancing cassette.

The ski is inserted by hand with the ski tip first.

Functionality:

- Easy and clear operation
- Individual and comfortable programming and saving of all structures.

3 Technical description

3.1 Technical data

Type Race NC	
Electrical rating	
Nominal voltage, frequency	3/AC 220-400 V, 50/60Hz
Power	5.7 kW
Nominal current	18.1 A
Fuse protection min. - max.	25/32 A
Safety information see chapt. 4.4.1 Power supply, page 24	
Dimensions	
see following graphics Working height depending of the setting of the adjustable feet from 1000 mm to 1030 mm (39.4 in - 40.6 in)	
Coolant container volume	150 liter
Total weight	
without coolant	about 1080 kg (2380 lbs)
Ski	
Ski length min. - max. with centerings	1400 mm - 2950 mm
Ski length min. - max. with v-rollers	1200 mm - 2950 mm
Ski width min. - max.	25 mm - 140 mm
Permissible ambient conditions	
The machine may only be used indoors!	
Temperature range	+ 5 to 40 °C
Humidity	5 ... 80% (entire temperature range)
Display	
Color display	15.4 " Touch screen display
Buffer battery	Lithium button cell, order number 15-480-106
Port	
USB port 1.1 / 2.0	Software updates, data backup
Grinding data	
Grinding stone diameter max./min.	350/300 mm
Grinding stone width	150 mm
	Optional for cross country ski 70 mm

Type Race NC	
Grinding rpm stone Dressing rpm stone	100 - 1000 rpm 200 - 1800 rpm
Dressing speed	1 - 50 mm/s
Diamond feed motion (integrated diamond cooling)	0.002 mm to 0.2 mm (Diamond feed in 0.001 steps)
Feed	
Feed speed	3 - 20 m/min
Contact force feed	40 to 400 N
Feed roller gummed	Ø 245 mm
Feed roller Go Kart tire (Option)	Ø 249 mm (0.5 bar tire pressure)
Other data	
Noise emission	In an average grinding process the continuous pressure sound level is approx. 74 dB(A) at a distance of 1 meter (3 ft).

Subject to technical changes.

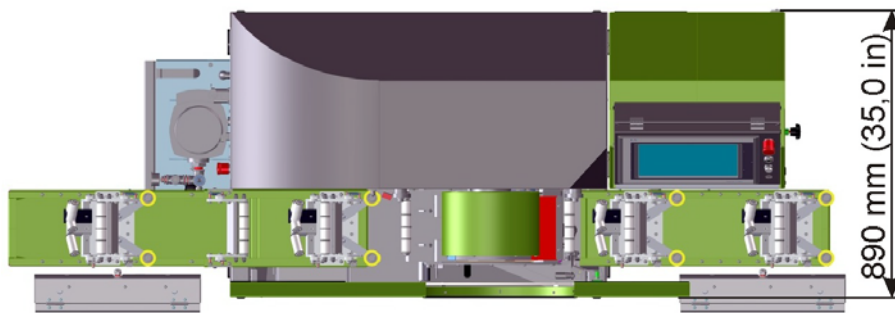
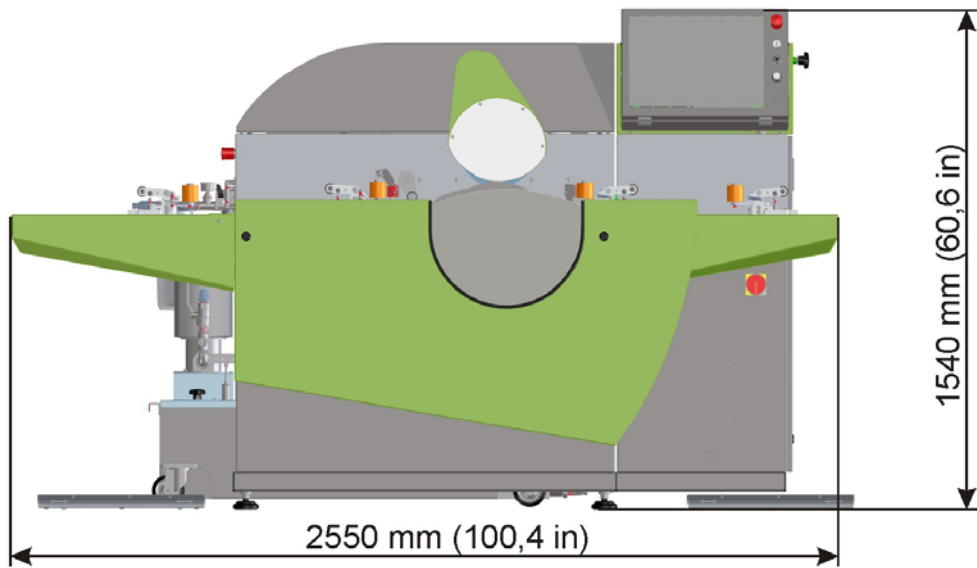

3.2 Machine overview

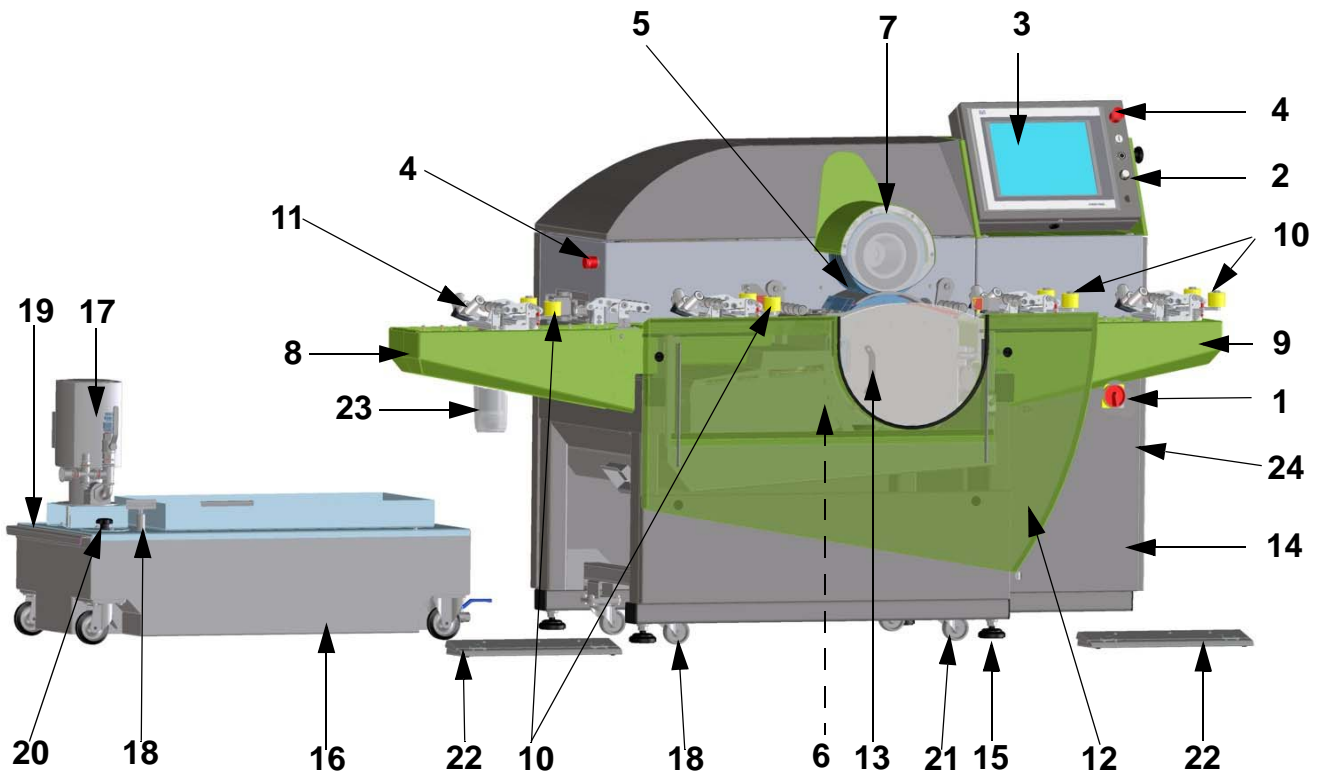

- | | |
|---------------------------|--|
| 1) Main switch | 13) Stone coverage |
| 2) Operating panel | 14) Control box |
| 3) Touch-Screen-Monitor | 15) Adjustable feet |
| 4) Emergency stop switch | 16) Coolant container |
| 5) Grinding stone | 17) Immersion pump |
| 6) Dressing unit | 18) Level indicator |
| 7) Feed roller | 19) Temperature indicator |
| 8) Input pan | 20) Magnetic bar |
| 9) Output pan | 21) Transport rollers |
| 10) Centerings | 22) Feet pedals (for starting and stopping the grinding cycle) |
| 11) V-rollers | 23) Water filter |
| 12) Main protective sheet | 24) Type plate |

4 Commissioning

4.1 Preparations for the transport of the machine



To avoid damages of the machine when transporting, the following arrangements have to be done.



A

- 1) Clean and conserve the machine and dry the grinding stone long ([see chapt. Time for dry-clean \(long\), page 50](#))
- 2) Move the dressing diamond to the neutral position ([see chapt. 9.10 Neutral position, page 55](#))
- 3) Switch off the machine on the main switch.
- 4) Turn the operating panel [A] to the transport position



Fill the distance between the touch screen monitor and the sheet bottom with foamed plastic.

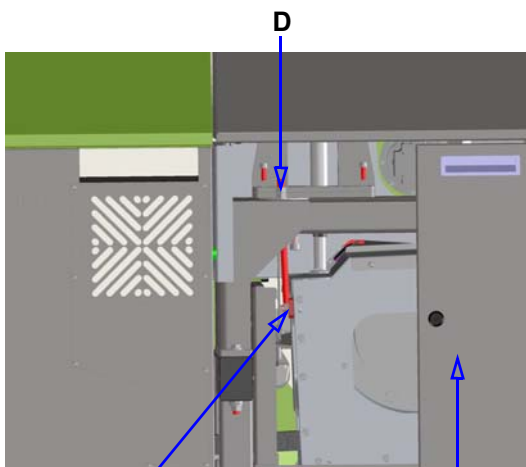

C

B

Mount the transport guard for the force control

- 5) Dismount the rear guard [B].
- 6) Mount the transport guard [C] with 4 screws.
- 7) Screw in the upper nut [D] as far as the lifting motor with the load cell unloaded and dangles free.
- 8) Counter the safety rails with the lower nut to fix the unit.

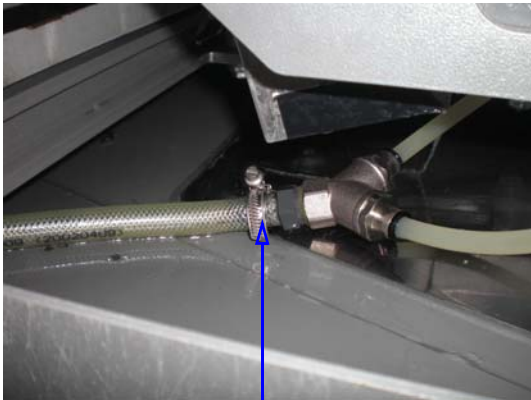

E

Discharge the water circulation

If the machine is transported at sub-zero temperatures, the water circulation has to be discharged.

- 9) Open the hose clip [E] on the Y-splitter under the grinding stone and discharge the hose.

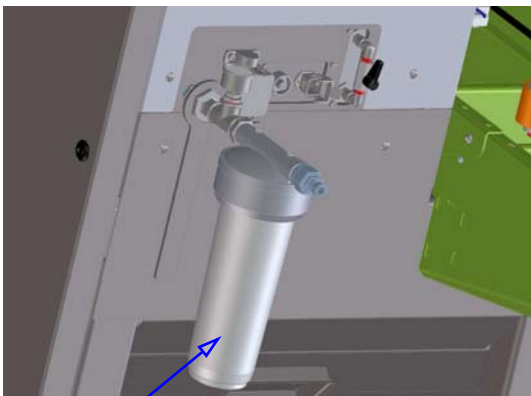

F

- 10) Dismount the filter [f] with the integrated key and discharge.



- 11) Disconnect all connection from the machine ([see chapt. 4.4 Connections and other preparations, page 23](#)).
- 12) Pull the water tank out of the machine and clean it.

Transport

- [see chapt. 4.2 Transport, page 20](#)

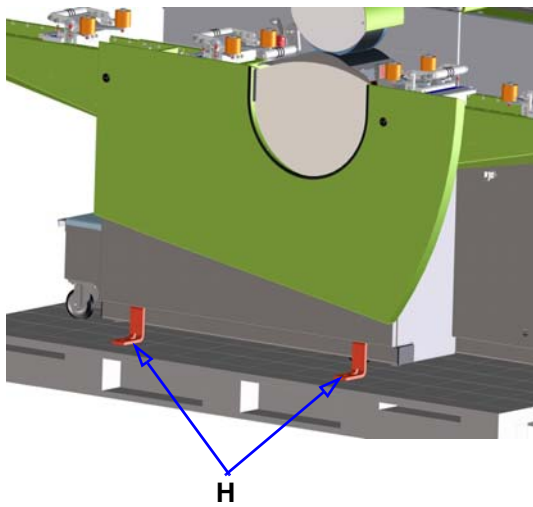

- 13) Lift the machine onto a suitable pallet.
- 14) Fix the machine with the fixing clips [H] on the pallet.
- 15) Store all needed materials (pedals, ...) in the water tank, move it under the machine and secure with a wooden block against rolling out.



For re-commissioning the machine remove the transport guard for the force control!

4.2 Transport



Please observe safety instructions ([see chapt. 2.2.3 Transport safety information, page 8](#))!

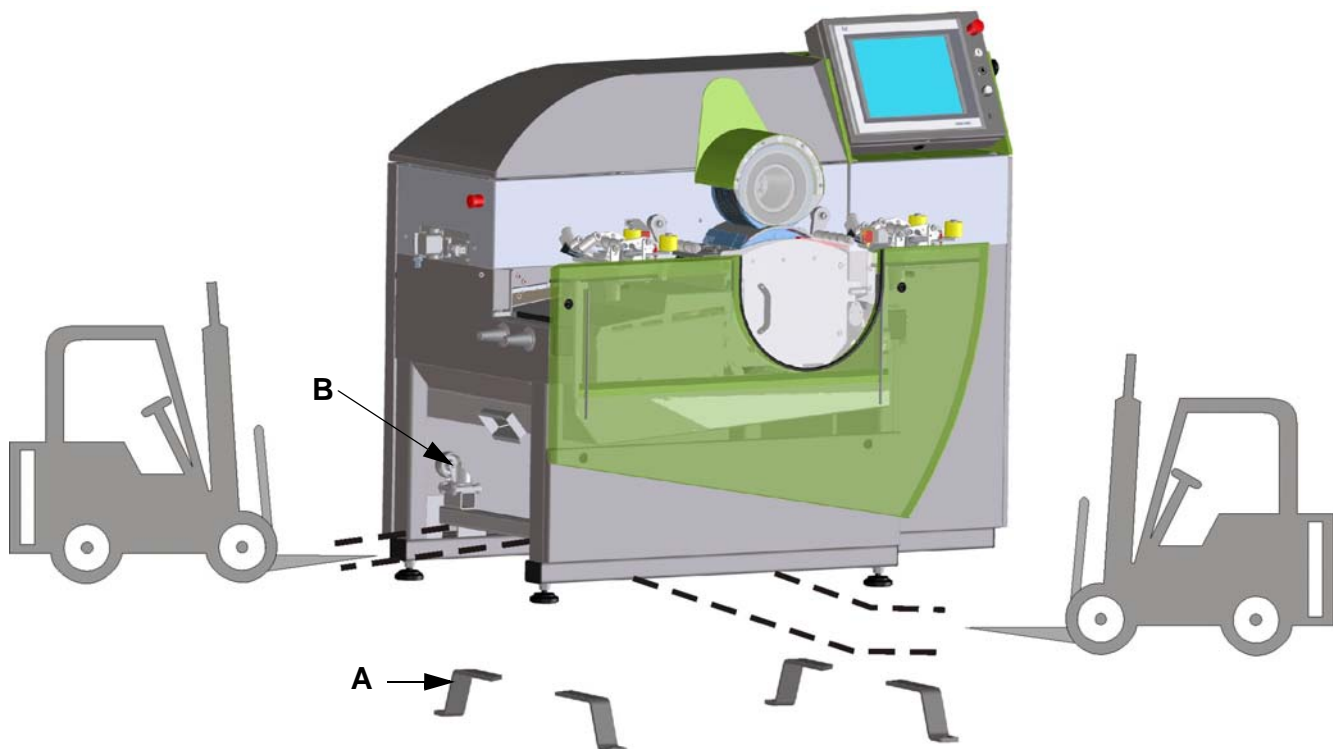
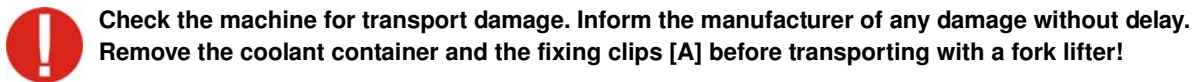

- Please use a forklift truck or fork stacker for transport of the grinder.
- For the alongside transport of the machine with a fork lift, the transport rollers [B] have to be rotated upwards.
- For disarranging a machine on an even ground the transport rollers [B] must be rotated downwards (adjustable feet have to be completely screwed in).

4.3 Installation

- Check the machine location to ensure that it is flat and that its load-carrying characteristics are adequate. In case of doubt, carry out a static test.
- The location has to be free from vibrations, they will have an affect to the grinding result. The ground may not transform or amplify vibrations.
- The work place is in front of the machine.

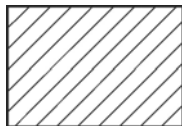
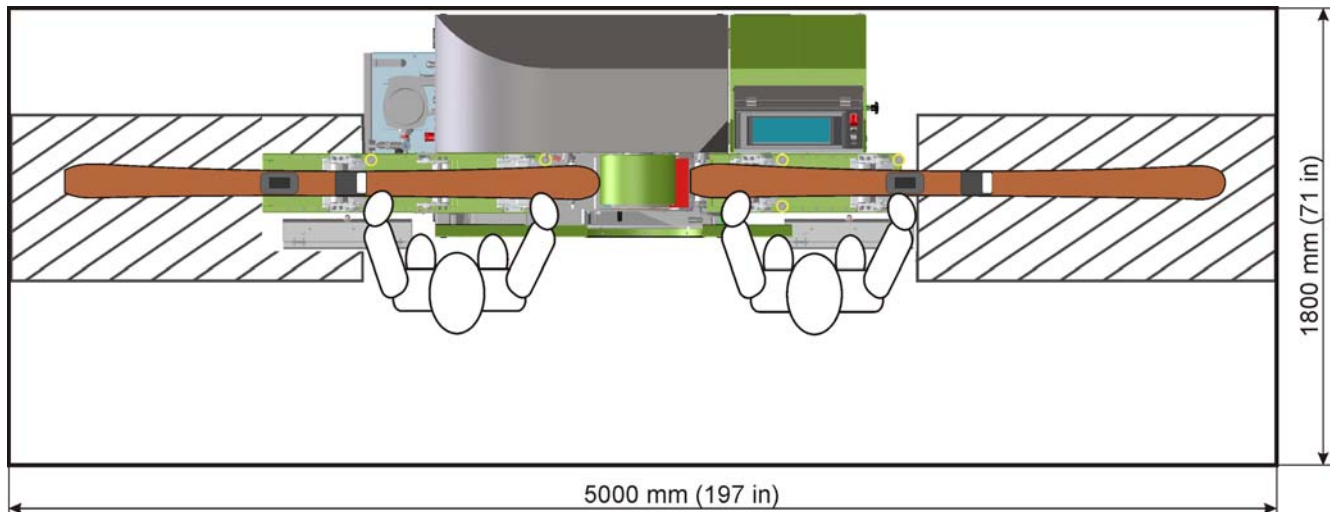

The **BLOCKED AREA** may not be accessed during the grinding process, because the ski may be ejected in case of poor feed adhesion.

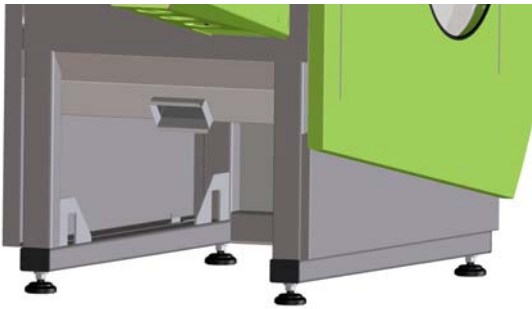

- Level the machine with the adjustable feet horizontally and vertically using the water-level [1] on the machine!

The working height can be adjusted by setting the adjustable feet to a height between 1000 mm and 1030 mm.

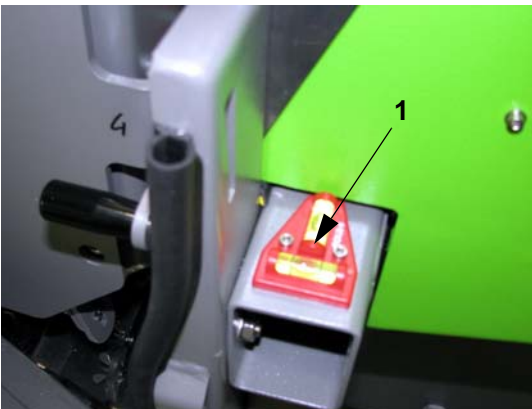

4.4 Connections and other preparations

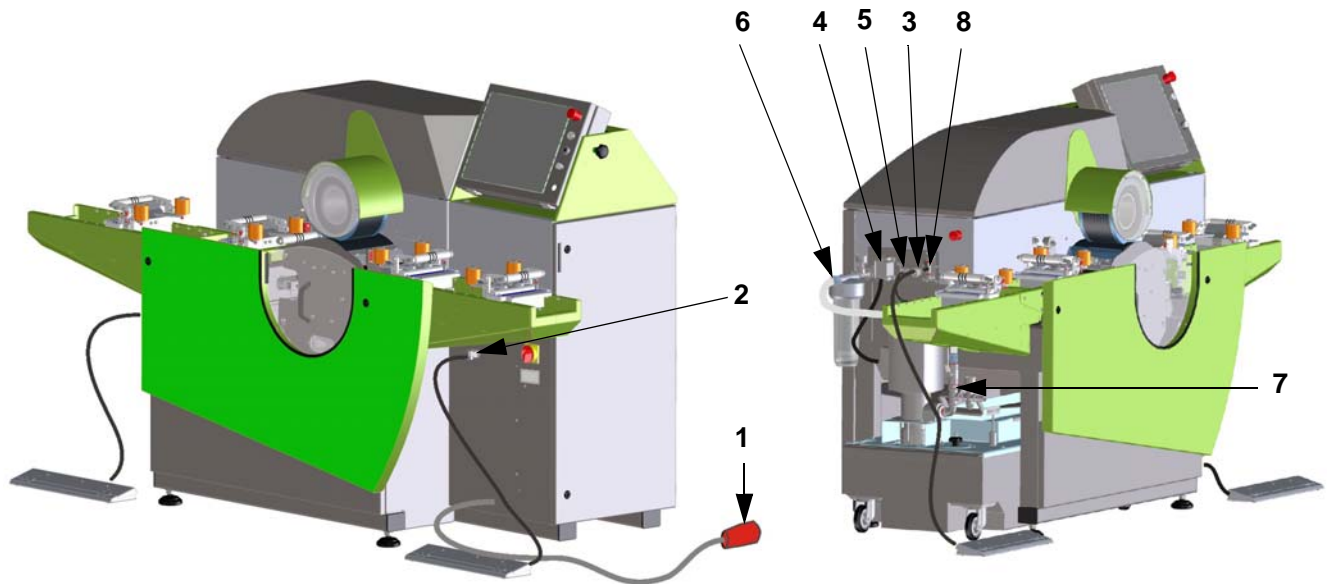

Figure (1)



Ensure that the supply voltage is correct!

The connection values are shown on the data plate near the main switch.

The installation must be performed by a qualified electrician!

It is recommended not to use residual current monitors because frequency converters in combination with line filters are used for speed control. The direct current proportion reduces the sensitivity of the residual current circuit breaker in case of an error. The local rules and regulations must be observed for the protection measures. However, if residual current monitors are mandatory for safety related reasons, only those monitors may be used, which are suitable for direct current, alternating current and high frequency ground current (e.g. ABB series F804 or equivalent equipment).

Recommended are residual current circuit breakers with a rated current of ≥ 300 mA.



If a residual current circuit breaker with a rated current of ≥ 300 mA is not allowed for a plug connection because of local rules and regulations, the machine has to be connected firmly!

- 1) Power supply cable
- 2) Connection foot pedal right
- 3) Connection foot pedal left
- 4) Power supply immersion pump
- 5) Connection temperature sensor wire coolant
- 6) Water supply immersion pump
- 7) Connection cleaning hose
- 8) Ball valve for diamond spraying

4.4.1 Power supply

The machine may only be connected directly to earthed three-phase industrial networks (TT, TN - these are three-phase supply networks with an earthed neutral point).



ACOPOSmulti drive systems may only be operated directly on earthed three-phase industrial networks (TT, TN-S, TN-C-S).



ACOPOSmulti drive systems may not be operated directly on IT- and TN-S networks with earthed outer conductor and protective earthen conductor.

i In non-earthed IT-networks (three-phase networks without an earthed neutral point resp. with an earthed neutral point via impedance) or in TN-S networks with an earthed outer conductor and protective earthed conductor isolating transformers have to be used, whereat the star point has to be earthed on the secondary side and has to be connected with the protective earthen conductor of the ACOPOSmulti drive system.

4.4.2 Coolant container

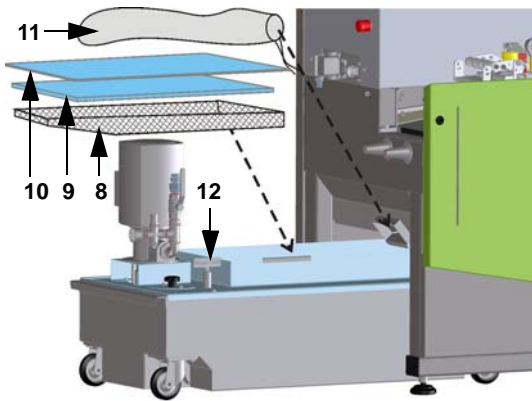

- Fill the coolant container with about 150 liter of water-emulsion-mix. Please note the coolant level according to the mark on the level indicator [12].
A water connection nearby simplifies changing and refilling of the coolant!

! **Danger of corrosion!**
Use only a water/emulsion mixture! Under no circumstances, can the machine be operated or cleaned with water only!
Observe mixing ratio according to data on emulsion tank.

- Connect the immersion pump according to figure 1 ([see chapt. 4.4 Connections and other preparations, page 23](#)), pos 4 and 6
- Insert the filter sieve [8]
- Insert the filter mat [9] (order number: 50-400-185)
- Stretch the filter fleece [10] over the filter mat and the filter sieve (order number 37-600-121)
- Fix the filter sock [11] on the outlet (order number 55-635-180).

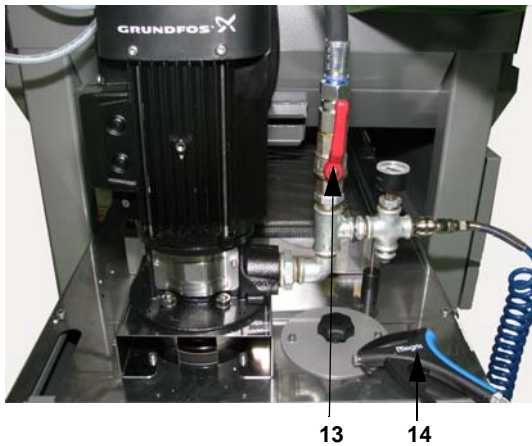

Ball valve coolant supply [13] - stone high pressure nozzle

- This lever regulates the amount of coolant supply to spray nozzle, stone aggregate. Spraying unit for grinding stone should be completely open if possible.

i Close the ball valve [13] when cleaning the machine with the cleaning hose [14]!

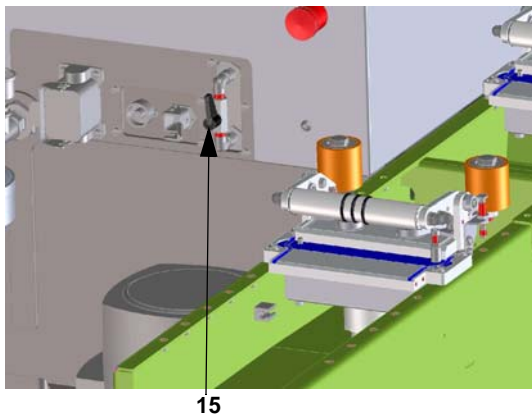

Ball valve for diamond spraying [15]

- With this lever you regulate the amount of coolant for the diamond spraying.

4.4.3 Ski centering with V-rollers

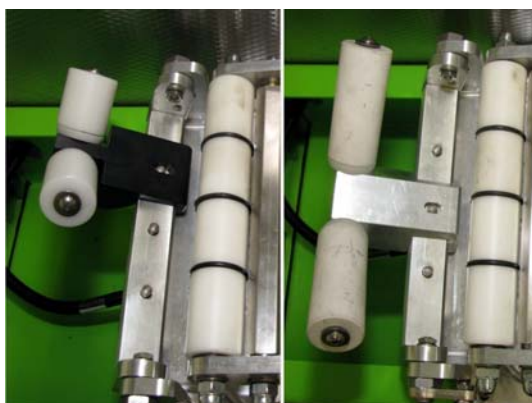

If you want to grind without automatically centering, this function has to be set in the program [\(see chapt. 7.2 Process display, page 45\)](#).

For alpine ski and ski-jumping ski place the broad v-roller [15] concentric in front of every supporting roller.

For cross-country ski place the small v-rollers [16] in front of every supporting roller left, right or concentric.

4.4.4 Adjust the centerings for alpine and cross country ski

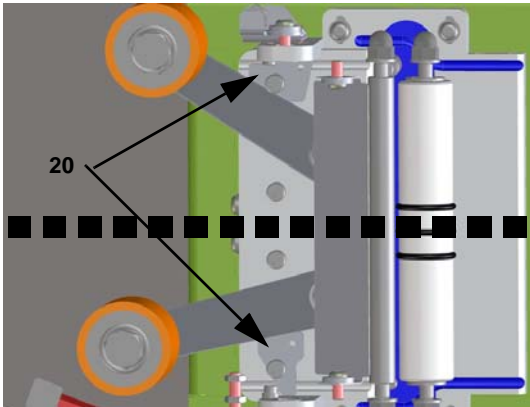

Alpine ski

- For alpine ski mount the stop plate [20] for the centering levers on both sides for all centerings as shown in the upper half of the illustration.
- Additionally the stop bolt [21] has to be attached for each centering outside and inside onto the set pin.

Cross country ski

- For cross country ski mount the stop plate for the centering levers on both sides for all centerings as shown in the lower half of the illustration.
- Remove the stop bolt [21] from each centering.

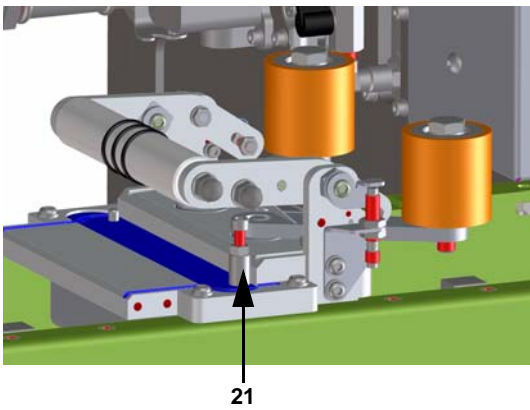

5 Description of the operating elements

5.1 Operating panel

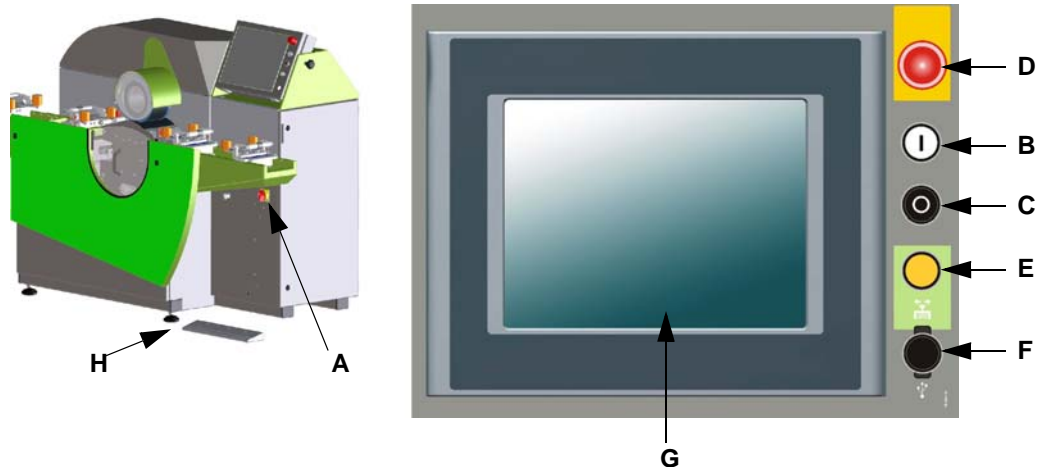

- A: Main switch
Switching the entire power supply on or off. When the power supply is ok, the start display is visible on the touch screen monitor.
- B: Start key
Switching on the machine. Feed arm, grinding stone and centerings move to their reference points. The editing display is now visible on the touch screen monitor.
- C: Stop key
When the machine is in the process mode it changes to the editing mode by pressing key [C].
When the key [C] is pressed while the grinding stone is rotating for dressing, facing or stone cleaning, the respective process is finished. Afterwards the splash guard cover is closed and the grinding stone is dry-cleaned before standing still.
When a ski is in grinding process, the process is finished, afterwards the splash guard cover is closed and the stone is dry-cleaned before standing still.
When the machine is in the editing mode the extended dry-clean ([see chapt. Time for dry-clean \(long\), page 50](#)) is executed.



The residual time of the dry-clean process is shown in the right upper part of the display in the editing mode.

- D: Emergency stop button
Switching the machine off in case of danger.



The emergency stop button can be fixated in the depressed position and the machine can no longer be switched on with the button [B]! Unlock the emergency stop button by pulling it out - switching the machine on with button [B] is now possible.

- When pressing the emergency stop button [D] the touch screen display changes to the starting display.

E: Start automatic mode

- Is the machine in the working mode and key [E] is pressed, the automatic mode, which is defined in the program, will run. Is the machine in the editing mode, the machine starts the working mode and asks if the automatic mode should be started.

F: USB socket

- USB socket for eventual program updates or for data exchange.

G: Touch screen monitor

- The touch screen function guarantees an optimal operation of the machine. A slight finger touch is enough to activate the desired field.



Never operate the touch screen with pointed objects such as ball point pens, knives, etc. As an option, a stylus produced especially for touch screens can be ordered at WINTERSTEIGER (order No. 7000-0811-V01).

H: Start the grinding process

- Put the ski with ski tip ahead onto the input pan till under the feed roller
- By pressing one of the feet pedals [H] the centerings close, when pressing for a second time the feed roller layers down and the ski is grinded in the selected program.
If one of the feet pedals is pressed for another time, the feed roller lifts up and the centerings open.

6 Loading - saving- deleting a grinding program



- Switch main switch on
The main display appears after a short initialization time.
- Press the start button.

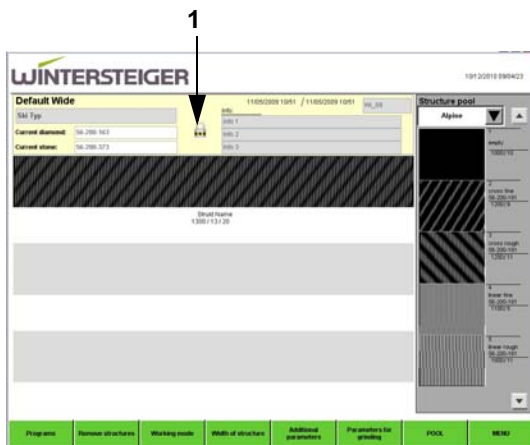

- On the touch screen the editing display with the last used program is visible.



If the lock [1] is locked, the grinding program is write-protected.

6.1 Loading grinding program



When pressing the button „programs“ a list of grinding programs preset by WINTERSTEIGER is opened.



The WINTERSTEIGER default programs are read-only (displayed green). They can be changed, however, they must be saved with a different name.

- Select the desired program by touching the row, then press the button „OPEN“.

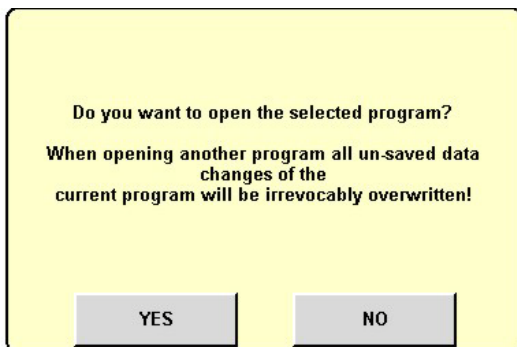

The adjoining message is displayed on the screen to ensure that possible changes in the previous program are not lost.

- The newly selected program will be opened by pressing the "YES" button. Changes in the previous program are not saved.
- You will return to the grinding program list by pressing the "NO" button, so that you can save the changed program.

6.2 Saving the grinding program

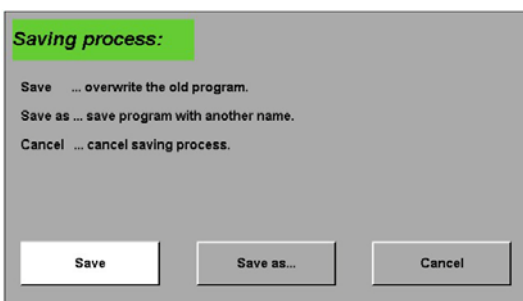

- When pressing the button „SAVE“ the following display is opened.
- The changed parameters and settings will be imported after the "SAVE" button is actuated. Afterwards you will be transferred back to the editing display.

i Only the "Save as" button is active because a read-only program was used in this example.

6.2.1 Save as

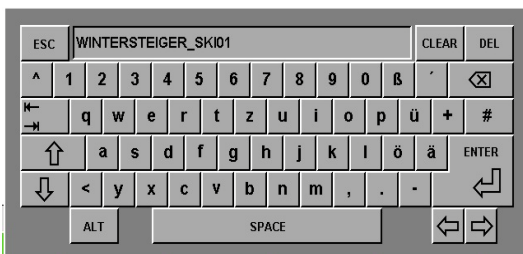

- The "Save as" button must be pressed to save a selected or changed program under a different name.
- An input window opens.
- Enter the desired identification.
- Switch between capital and lower case letters by using the "↑" button.
- Use the "ESC" key to cancel.
- The input will be confirmed by using the "ENTER" key.

6.3 Delete a grinding program



- The list of grinding programs opens when the "Programs" button on the main display is pressed.

The current program will be displayed inversely on the list.

i The WINTERSTEIGER default programs are read-only and cannot be deleted.

- Select program and remove with the "Delete" key.

6.4 Lock and unlock a grinding program



- By pressing the lock-symbol [1], the request, if the grinding program should be locked, is shown.
- Is the write-protection confirmed with „YES“, the grinding program is write-protected after saving.

It is possible to unlock the grinding program by pressing the lock-symbol [1] and entering the password „4900“ in the password window.

6.5 Saving a grinding program on an USB-stick



- Switch on the USB stick into the USB-port on the operating panel. After a short waiting time the USB stick is identified by the system.
- Press the button „Programs“ on the editing display.

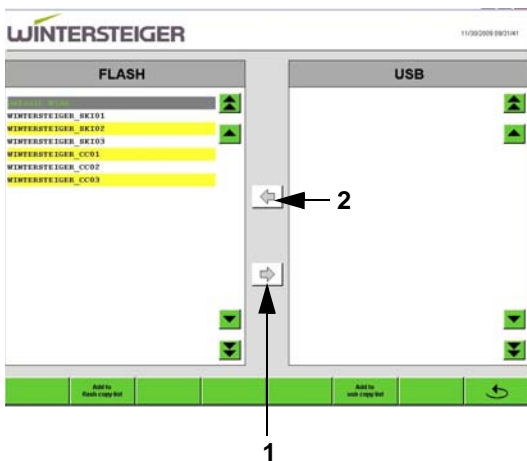

- By pressing the button „Copy files...“ the copy list is opened.

If no USB stick connected, an error message will appear.

On the left side the grinding programs on the machine memory (Flash) are visible.

- Mark the grinding program which should be copied with the finger. By pressing the button „Add to flash copy list“ to mark the line yellow.
- By pressing the arrow-button [1] to copy all yellow marked grinding programs to the USB stick.

If no USB stick is connected, the following error message will appear: Copy operation isn't possible. USB - stick isn't plugged.

To copy a grinding program from an USB stick to the machine memory (Flash) mark the grinding program on the right side and press the arrow-button [2].

i Only remove the USB stick after leaving the copy list with the button "  ", because the encryption of the grinding programs starts when leaving the copy list.

6.6 Loading a grinding program from an USB stick



- Switch on the USB stick into the USB-port on the operating panel.
- By pressing the button „Programs“ a list with grinding programs is opened.
- By pressing the button „Change to ... USB“ a list with saved grinding programs on the USB stick is opened.
- Choose the program and open with the button „Open“.

i To encrypt the grinding programs on the USB stick after the grinding process, it is necessary to change to the machine memory (Flash) with the button „Change to ... Flash“ [3] and remove the USB stick afterwards.

6.7 Program info

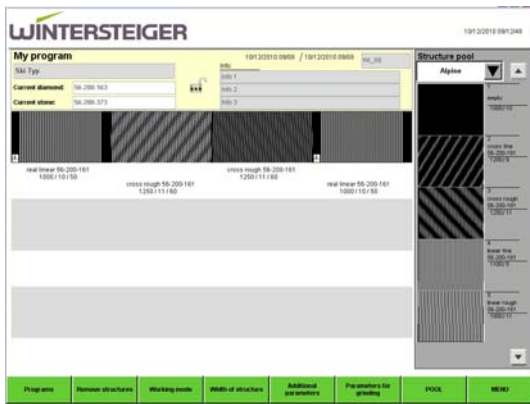

- When pressing on one of the three info text lines on the editing display an input field is opened, in which program information can be entered.

6.8 Information about the input fields

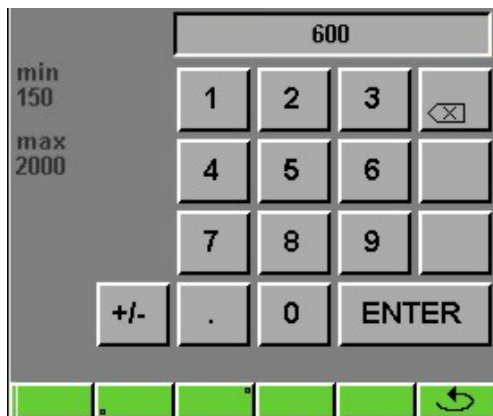

If an input field is actuated, a number block appears on the display, which is used to enter the desired number. Each input must be confirmed with ENTER.

Use the "↺" button to exit the window without assuming the changed values. The minimum and the maximum input value will be displayed for each input field at the upper left of the display.

7 Changing a grinding program

7.1 Editing display

In this display all parameters for the grinding process are set.

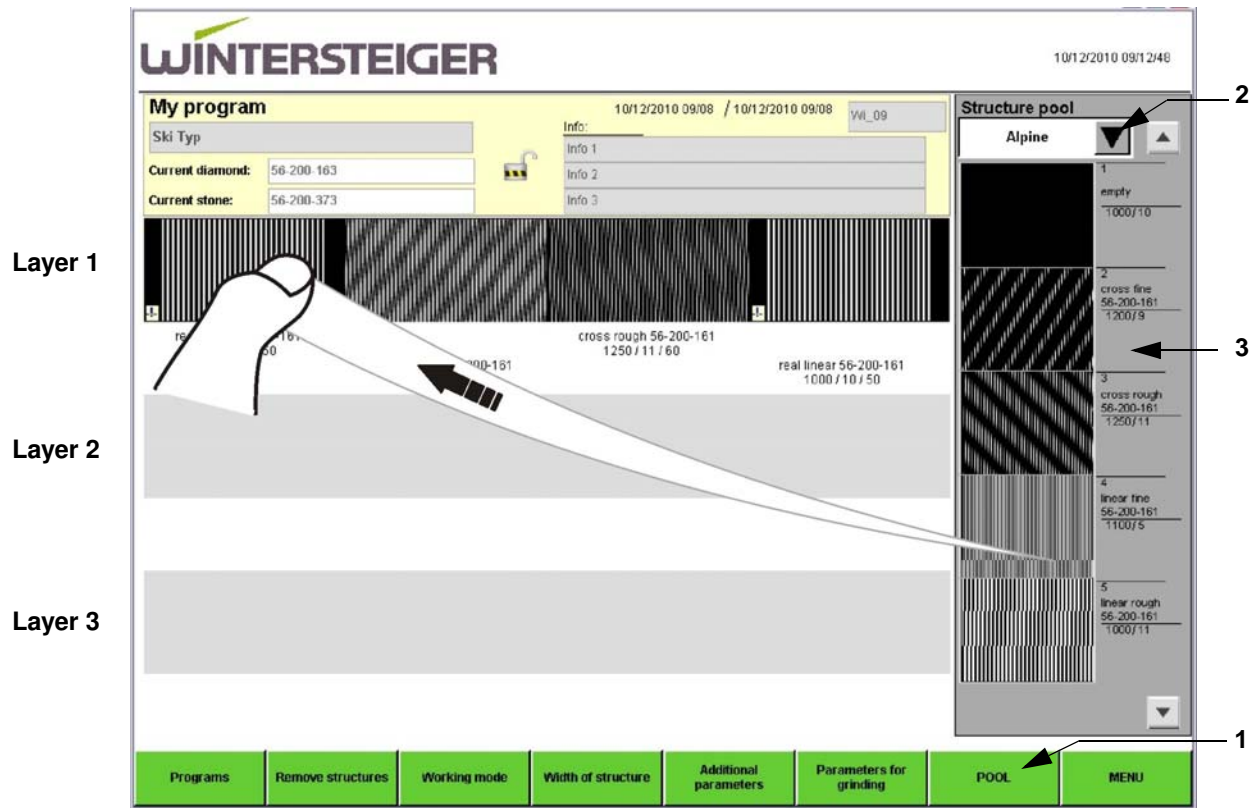

7.1.1 Structure layers

- It is possible to put 3 structures on top of each other. At first the structure of the first layer is dressed on the stone, following the structure of the second layer and as necessary the structure of the third layer.

7.1.2 Loading a structure

- By pressing the button „POOL“ [1] the structure pool window is shown.
- In the list field [2] 6 predefined structure pool can be selected.

In the both pools alpine and nordic are 10 predefined structures whose structure characters and parameters cannot be changed. They are only templates. Changed structures can be saved in the pools „User 1“ to „User 4“.



By pressing the lock-symbol [3] the structures in the pools „User 1“ to „User 4“ can also be locked.

To load a structure into an existing program, pull the desired structure with the finger from the structure pool in one of the three layers in the editing display. The structure name, dressing rpm, dressing speed and diamond motion feed is shown under the structure picture. It is possible to scroll in the structure pool with the lateral arrow buttons or pulling with the finger up and down.

7.1.3 Combined structures over the stone width

To combine several structures over the stone width (for example layer 1), pull the desired structures with the finger from the structure pool into the desired layer. Up to 6 structures are possible in one layer. The widths of the structures are automatically distributed on the whole width.

7.1.4 Changing the structure width

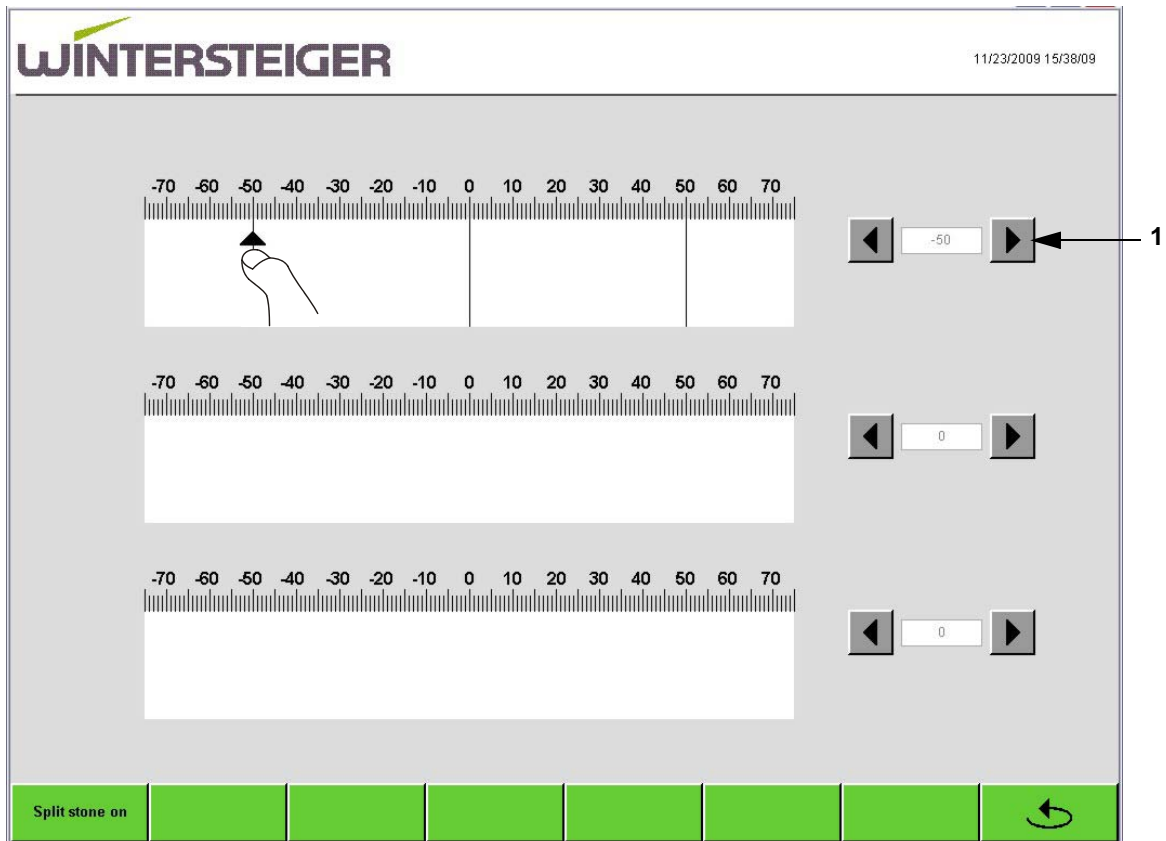

- Mark the line of the structure width, which should be changed with the finger.
- With the cursor buttons [1] of the respective layer the marked line (arrow) can be moved.

Split stone on

- By pressing the button „Split stone on“ the stone is split centric.

This is used for example for grinding cross-country ski, where a structure for pregrinding is dressed to the backmost half of the stone and a structure for fine grinding is dressed on the front half of the stone.

- When pressing the button „Split stone on“ again, the splitting of the stone is revoked.

7.1.5 Changing structure parameters

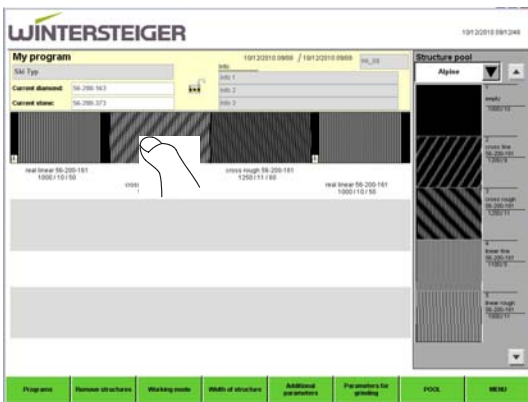

- When tapping twice on the desired structure (e.g. layer 1) the structure parameters are shown and can be changed in the loaded grinding program.

i Changes of the structures in the pools „User 1“ to “User 4“ can also be done when tapping twice to the desired structure in the pool window.

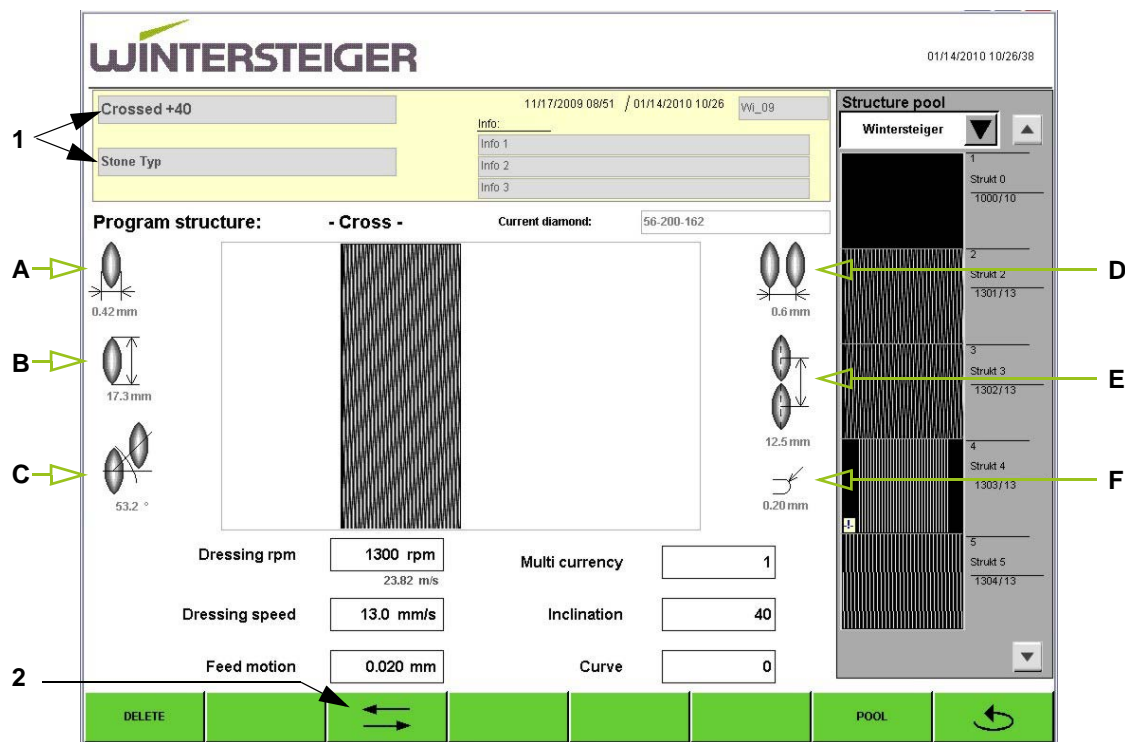

i In this chapter all structure parameters are described. Depending on the selected structure only the needed parameters are shown.

- By pressing on one of the text lines [1] an input field is opened, in which the structure name and the structure information can be typed.

Additionally the following structure information are shown:

A: Groove width in mm	B: Groove length in mm
C: Structure inclination in °	D: Transverse shuttle distance in mm
E: Longitudinal shuttle distance in mm	F: Diamond radius in mm

7.1.5.1 Standard parameters

Dressing rpm

- In the input field „dressing rpm“ the revolutions per minute of the stone are adjusted. Input area between 200 and 1800 rpm.

Dressing speed

- In the input field „dressing speed“ the speed of the dressing diamond is adjusted. Input area is between 1 and 50 mm/s.

Speed in and speed out for dressing

Instead of the inclination and the dressing speed also the speed in and speed out can be entered.

- By pressing the button [2] an input field opens, in which the speed in and the speed out can separately be entered.



This input is only possible for a cross structure. When changing the inclination and the dressing speed are adjusted accordingly.

Feed motion

- In the input field „feed motion“ the structure depth (diamond feed) is adjusted.

Multi currency

In the input field „multi currency“ the number of dressing processes on the stone are adjusted.

for example:

- Input (1) = Standard stetting, one dressing process
- Input (2) = two dressing processes, but the starting point of the second dressing process is shifted by 180° along the stone outline.
- Input (3) = three dressing processes, but the starting point of the second and third dressing process is shifted respectively by 120°.

This can be interpreted as a multiple thread and the dressing speed has to be increased.

Recommendation:

Dressing speed > 15 mm/s

Dressing rpm < 1000 r/min

7.1.5.2 Parameters crossed structure

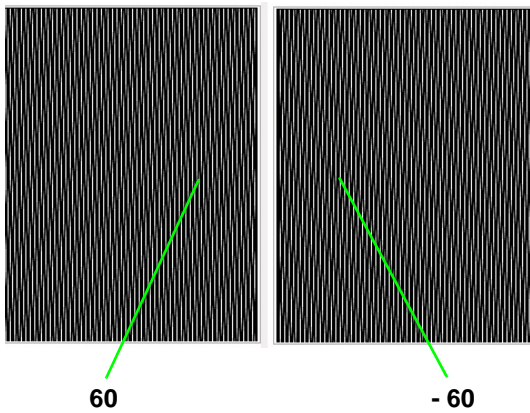

Inclination of the structure

- In this input field the inclination of a crossed structure is changed.

for example:

- Positive value: the structure takes course to right
- Negative value: the structure takes course to left
- Value 0: straight-crossed structure



This value is not indicated in degrees!
The effective inclination is also impacted by the dressing rpm and the dressing speed.

Curve

- In this input field the curve of the selected structure is selected.

for example : input 50



For defined input values the displayed curve is not the curved structure, which is grinded onto the ski.

7.1.5.3 Parameters wave structure

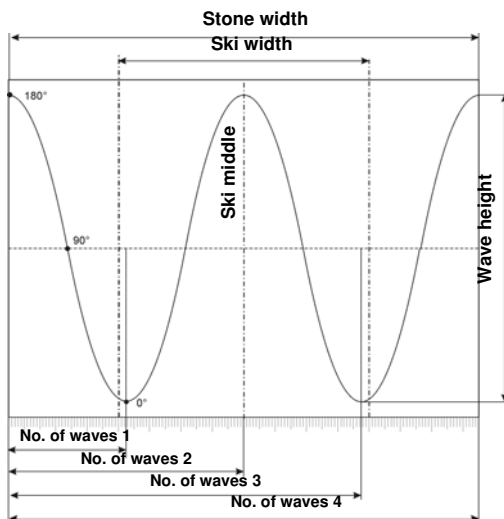

Wave height

- In this input field the wave height is adjusted.
A negative value e.g. 100 reflects the wave around the horizontal axis.



The wave height also depends on the feed speed and the grinding rpm.

Number of waves

- In this input field the number of waves over the stone width is adjusted.

Wave position

- In this input field the wave is moved off-center.

7.1.5.4 Parameters linear structure

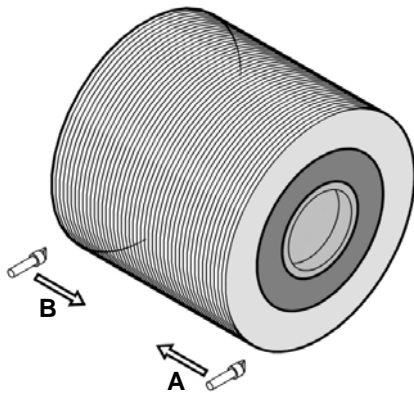

Direction of motion

- In this list field the direction of motion of the dressing diamond is defined.
- A: In
- B: Out

7.1.5.5 Parameters real linear structure

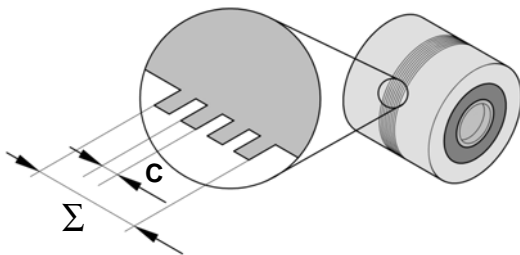

Groove length [C]

- In this input field the groove length (slot on the ski) is adjusted.

Number of grooves [Σ]

- In this input field the number of groove on the defined structure width are adjusted.

i The division of the grooves happens from center of the pre-set structure width.

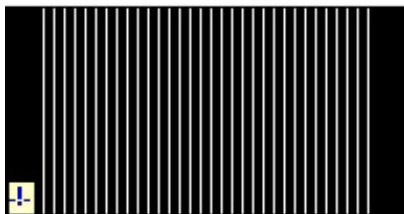

If the real linear structure can not be displayed correctly in the structure preview on the display, a „!“ is shown.

! = Distance left - right could not be shown correctly.

7.1.5.6 Structure info

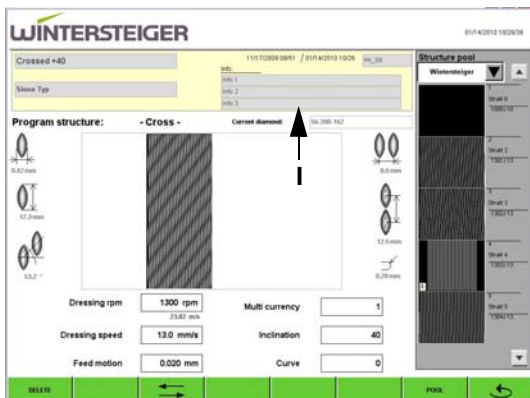

- By pressing on one of the three info text lines [!] on the structure display an input field is opened, in which the structure information can be entered.
- Use the "↻" button to exit the window. The changed structure parameters are assumed to the grinding program.

7.1.5.7 Deleting a structure

- Use the button „DELETE“ in the structure display to delete the structure from the structure level.

7.1.5.8 Saving a structure in the user pool

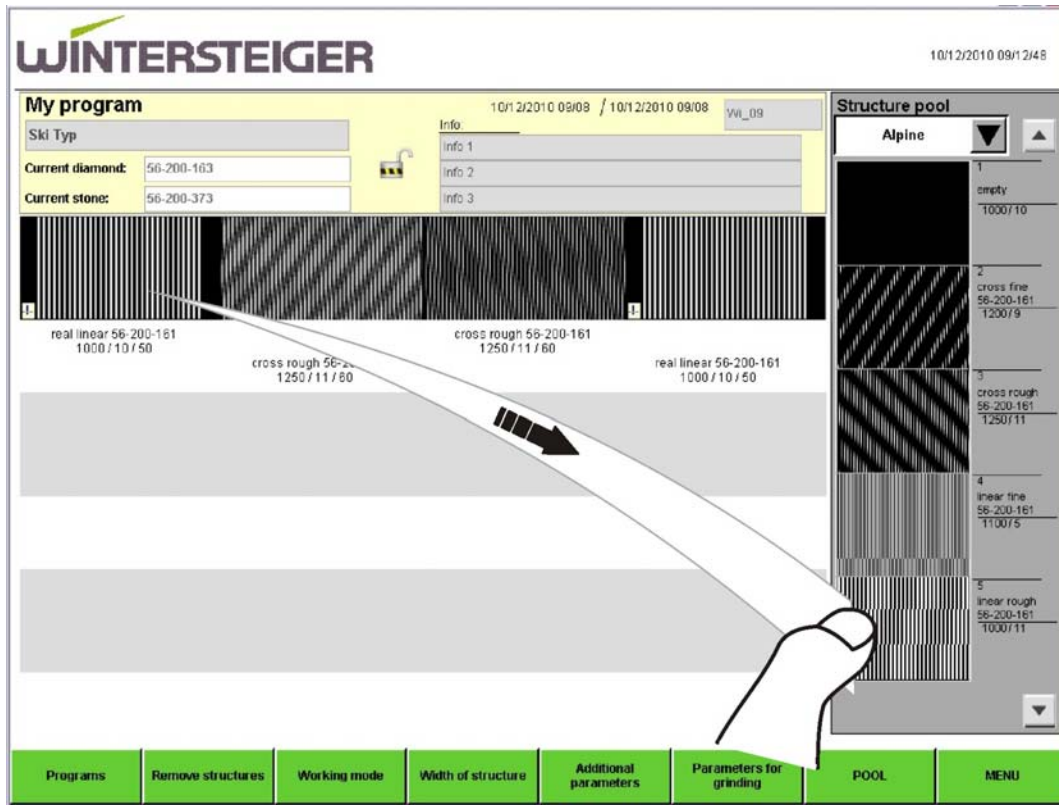

- To save a changed structure from program into the pool, pull the desired structure with the finger from the program to a non-used structure in the user pool: The following message occurs:

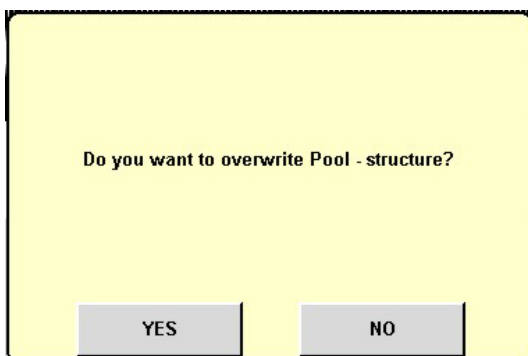

Press „Yes“ to overwrite the pool structure with the structure from the program.

Press „No“ not to overwrite the pool structure.

7.1.5.9 Copying and linking structures

For copying or linking structures pull the desired structure with the finger to the target area, where the copied or linked structure should be generated.

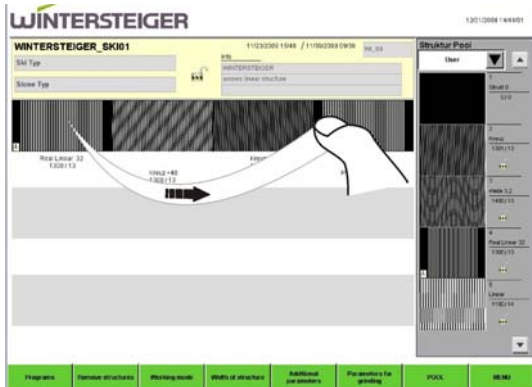

The following window is shown:

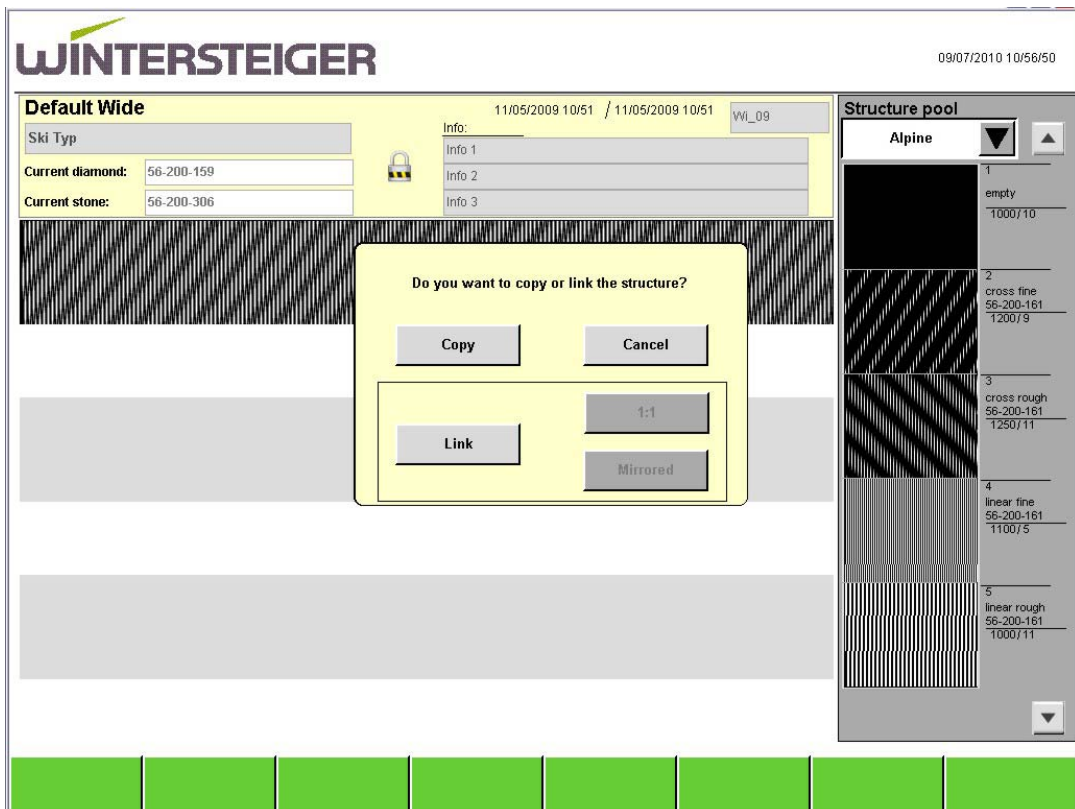

- The function „Copy“ copies the desired structure. When the initial structure is changed, the copied structure is not changed.
- The function „Link“ created a linked structure. With „Link“ either a 1:1 structure or a mirrored structure is created. When the initial structure is changed, the linked structure is also changed.

7.1.6 Grinding parameters

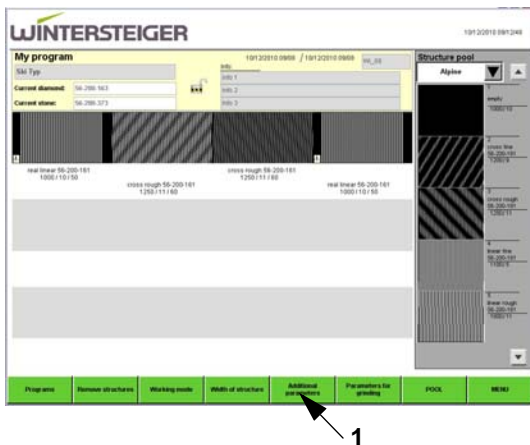

- By pressing the button „Grinding parameters“ [1] on the editing display the following window occurs.

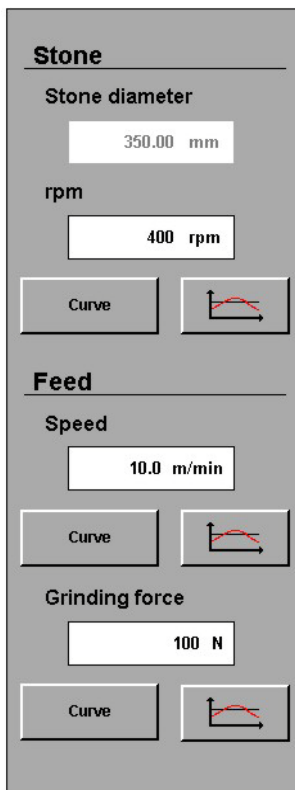

Stone diameter

- In this field the current stone diameter is shown.

Grinding rpm

- In this input field the grinding rpm is shown. In the subjacent field the cutting speed in meter per second is shown.

Grinding speed

- In this input field the feed speed is set.

Grinding force

- In this input field the grinding force is set.

7.1.7 Variable grinding parameters

With variable grinding parameters they can be set over the whole ski length.

Grinding rpm variable

With this function there is the possibility to set variable grinding rpm while grinding depending on the entered ski length.

Feed speed variable

With this function there is the possibility to set variable feed speeds while grinding depending on the entered ski length.

Grinding force variable

With this function there is the possibility to set variable grinding forces while grinding depending on the entered ski length.

- By pressing the button "  " the variable values get active instead of the fix values.

i The procedure for setting the variable grinding parameters is identical for all parameters, in the following example only the setting of the grinding force is described.

- By pressing the button "Curve" under the desired grinding parameters the following window is shown.

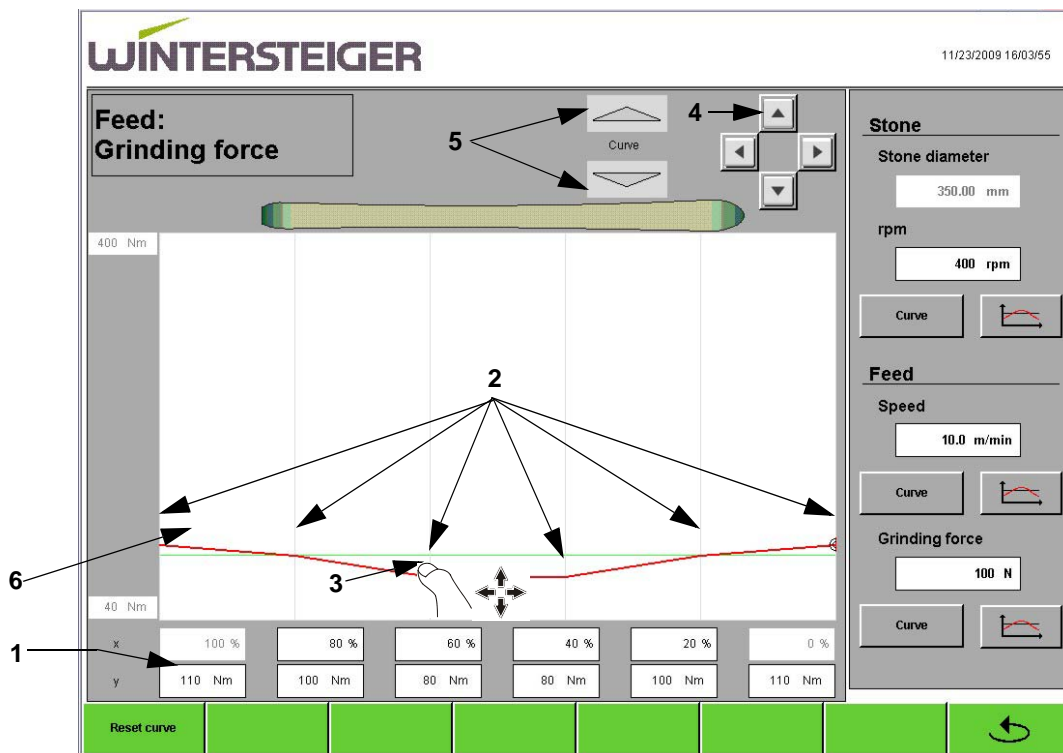

The whole ski length which is shown in percent [1] (100% = ski end, 0% = ski tip) is split in 6 preset points.

- By actuating one of the preset points a coordinate plane [3] with a red ring occurs. Based on the preset basis parameter [3] the coordinate plane can be moved with the finger to the desired place. Additionally it is possible to move the position of the coordinate plane [3] by pressing the cursor buttons [4]. Furthermore it is possible to section the coordinate plane [3] by an input of the values in the x/y lines.
- By actuating the buttons [5] the whole curve can be moved up or down depending from the preset basis parameters.
- The fix value [6] is shown by a green line.
- If the adjusted value (feed speed, grinding rpm) is not possible, an error message occurs.
- By pressing the button „Reset Curve“ the curve is flattened to the fix value and the preset points are split in 20% steps.
- Use the "  " button to exit the window. The changed parameters are assumed to the grinding program.

7.1.8 Facing parameters

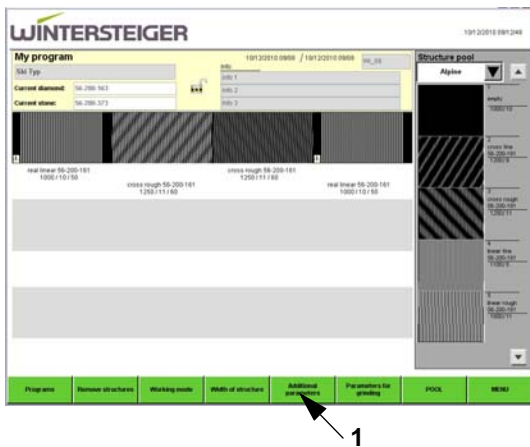

- By pressing the button „Additional parameters“ [1] on the editing display the following window is shown.

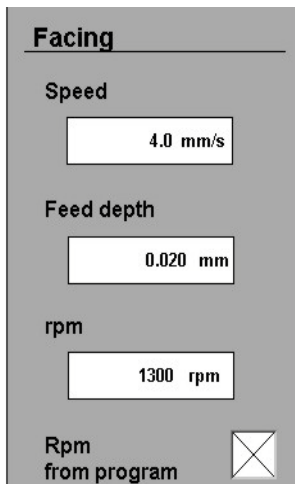

Facing speed

- In this input field the dressing speed of the dressing diamond when facing is set.

Feed motion

- In this input field the structure depth (diamond feed) when facing is set.

rpm

- In this input field the rpm of the stone facing is set.

Rpm from program

- By activating the check box the highest rpm from the loaded program is used. The rpm is shown and the input field is locked.

7.1.9 Layer offset

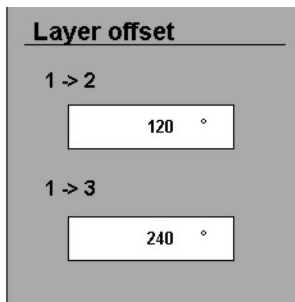

- Pressing the "Additional Parameters" [1] button on the edit screen opens the following window.
- If two or three structures are laid on top of each other, the layer offset determines where the diamond starts with the dress.
- The offset always refers to the first structure layer.

7.1.10 Removing structures

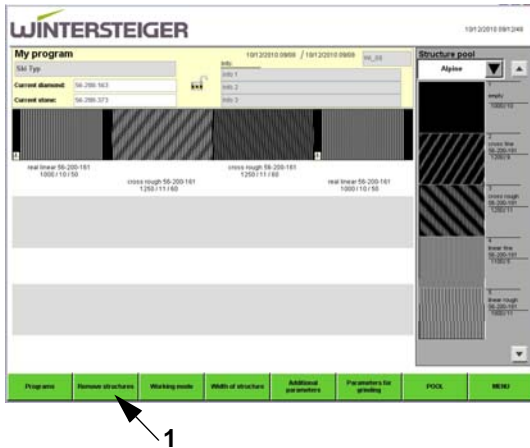

- By pressing the button „Remove structures“ [1] on the editing display all structures in current grinding program are deleted.

7.2 Process display

When all parameters in the editing display are set, press the button „process mode“ to open the window for the grinding process.

In this display the remaining parameters for the grinding process are set.

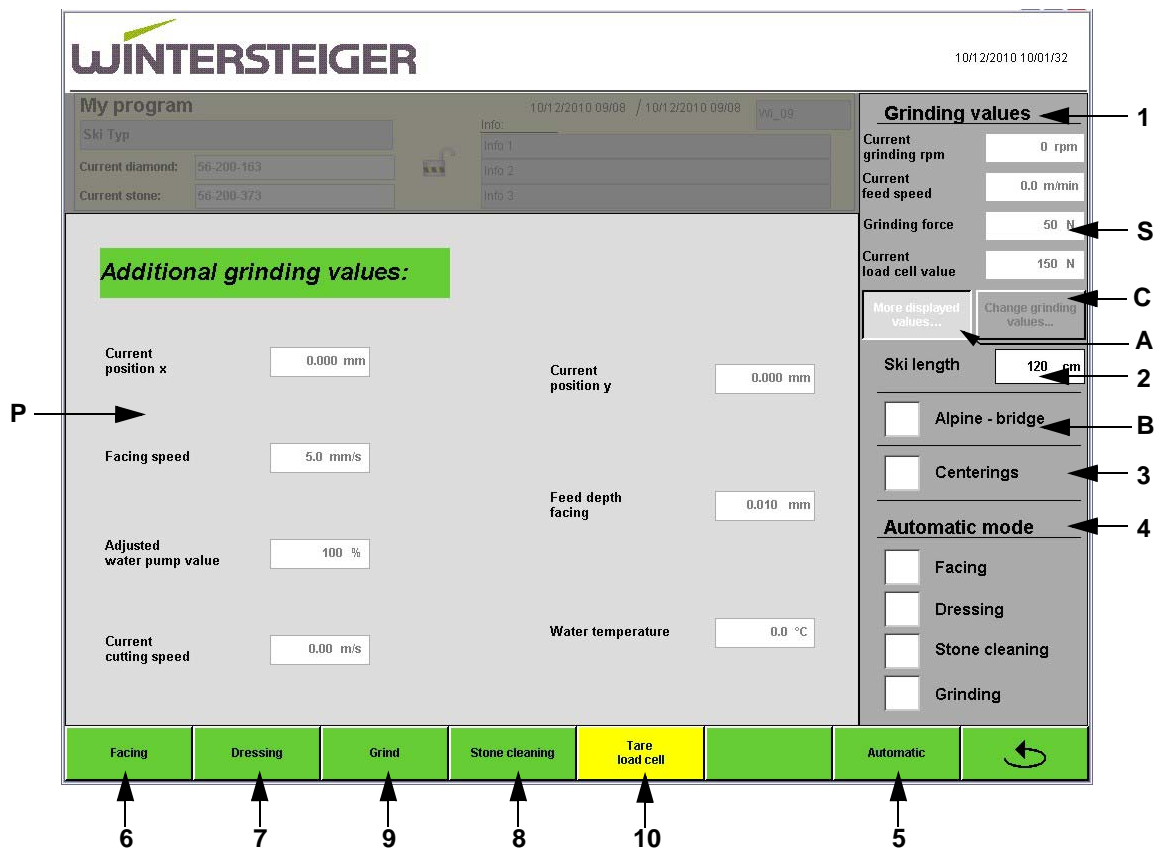

Grinding values [1]

While grinding the most important parameters are shown. Is the grinding force variable, this is shown with the curve symbol [S].

- By pressing the button „More values...“ [A] more parameters are shown in an own window [P]. By pressing the button „More values...“ once more the window is faded-out.
- By pressing the button „Change grinding values...“ [C] the temporary grinding parameters are displayed in an own window ([see chapt. 7.2.1 Change grinding values, page 47](#)).

Ski length [2]

Are variable grinding parameters used in the current grinding program, in this input fields the grinded ski length (without ski tip) must be entered.

Centerings [3]

Activate the field „Centerings“ with a tick [X] when grinding with centerings.



When grinding with centerings dismount the v-rollers!

Automatic mode [4]

- By pressing the button „Automatic“ [5] all individual steps (facing, dressing, dry-clean of the stone, grinding), which are selected with an „X“ are finished successively.
- The automatic mode is started when pressing the button „Start automatic mode“ on the operating panel.

Facing [6]

- By pressing the button „Facing“ the stone is faced with a very fine linear structure. That has the average that there is always the same starting base for the structure which is afterwards dressed to the stone.

Dressing [7]

- By pressing the button „Dressing“ the grinding stone is dressed with the preset parameters.

Stone cleaning [8]

- As long as the button „Stone cleaning“ is pressed, the grinding stone is cleaned with the stone cleaner.

Grinding [9]

- By pressing the button „Grinding“ the grinding stone is tuned to the preset rpm.

Alpine bridge [B]

- When an alpine bridge is used for grinding, the checkbox has to be marked with an X.
- The maximum feed speed is limited with 12 m/min, otherwise a warning message will occur.
- The minimum grinding force is 100 N otherwise a warning message will occur.

Tare load cell [10]

- Press button [10] to tare the load cell. The value is set to Zero. The taring takes a few seconds. During this time no load may be applied to the load cell.



At a difference of more than +/- 10 Newton, the button „Tare weighing cell“ is yellow highlighted.

7.2.1 Change grinding values

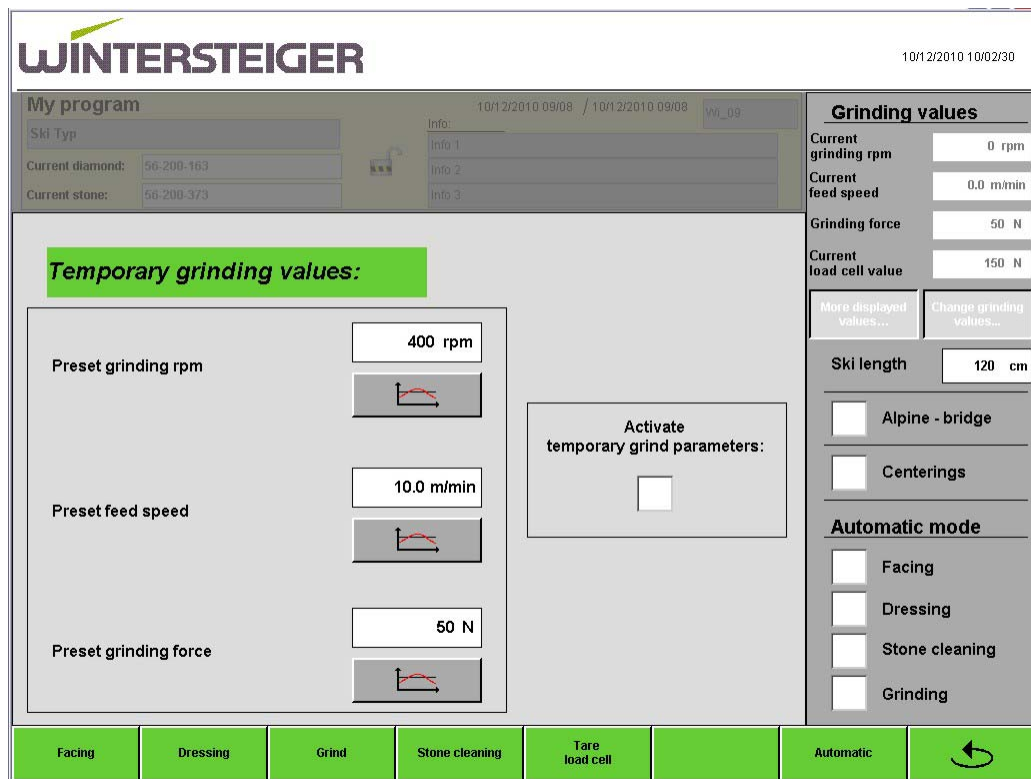

- In this window the grinding rpm, the feed speed and the grinding force can be changed. By activating the check box „Activate temporary grind parameters“ the entered values are used for the grinding process.

8 Working with the machine

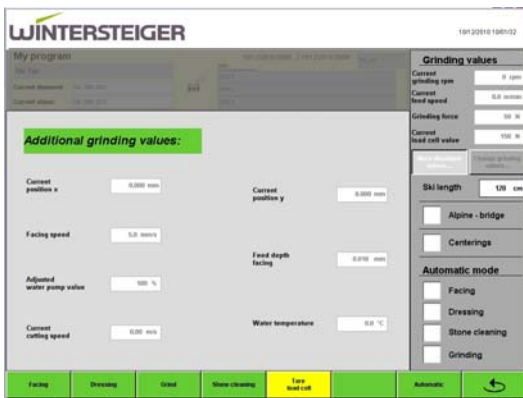

- Switch on the main switch.
- Press the start button on the operating panel.

On the touch screen the editing display with the last used program is shown.

- If necessary load a new grinding program or correct the structure and grinding parameters in the editing display.
- By pressing the button „Working mode“ on the editing display change to the process display.



When a new grinding program is loaded or the structure parameters are changed, the stone must be dressed.

- When variable grinding parameters are used in the current grinding program enter the ski length (without ski tip).
- Choose grinding with or without centerings
- If necessary mount the v-rollers
- Press the button „grinding“ on the process display.



When using an alpine bridge never attach the feed roller directly onto the alpine bridge. The machine can be damaged. The feed arm swings down very quick and the load cell would get a beat.



Check:

- if the ball valve for the coolant supply of the stone high pressure nozzle is opened.

- if at ski with binding the ski stop don't jut out and the ski are equipped with a binding bridge.



**On the steel edges of the ski you can hurt your hands.
Wear gloves!**

- Put the ski with the tip under the feed roller.



**Do not touch between the centerings and the ski or the feed roller
and the ski, you may hurt your hands.**

- Press the ski soft downwards and press the foot pedal.
The centerings close.
- When pressing the foot panel again, the feed roller lifts downwards.



**Guide the ski while grinding by hand. Remove the ski not
until the last centering is opened.**

9 General settings



- By pressing the button „MENU“ on the editing display the window Menu is opened.



The menu points „IBN-Menu“ and „System“ are only needed for the commissioning of the machine. They can only be activated by a WINTERSTEIGER technician when entering a password!

9.1 User settings

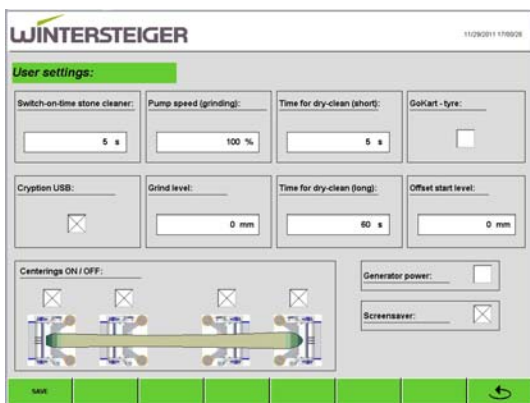

- By pressing the button „User settings“ the following window is opened.

Switch-on-time stone cleaner

- In this input field the stone cleaning time after the dressing process is set.
The range for the input value is between 2 and 30 seconds.

Pump speed (Grinding)

- In this input field the pump speed of the coolant pump is set in percent.
The range for the input value is between 50 and 100%.

Time for dry-clean (short)

- In this input field the time for dry-cleaning the grinding stone is set.
The range for the input value is between 1 and 30 seconds.

Time for dry-clean (long)

- In this input field the time for dry-cleaning the grinding stone is set.
The range for the input value is between 30 and 300 seconds.

Cryption USB

- To crypt programs which are saved on the USB stick this function has to be activated.

GoKart tyre

- Is a GoKart tyre used as the feed roller, this function has to be activated. To ensure an optimum contact between the GoKart tyre and the ski, the pressure of the tyre has to be at 0.5 bars.

Centerings ON/OFF

- With this option individual centerings can be deactivated.
- By pressing on a centering the following display is shown.

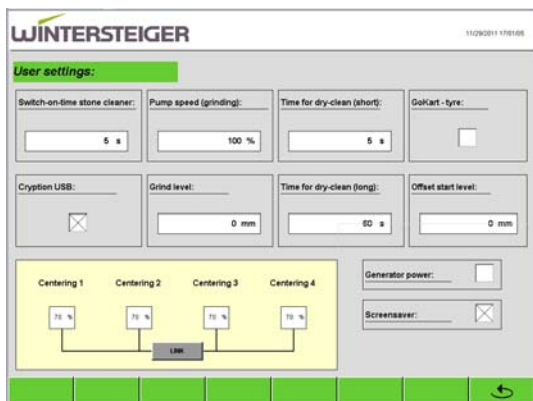

- Press the input field, which should be changed. The input is a percent value of the maximum pressure. The input range is between 50 and 100%.
- By pressing the button „Link“ the same value is applied for all centerings.

Grind level

When exchanging the feed roller for a go-kart wheel possibly the grind level (distance between feed roller and grinding stone) has to be changed, because the diameter is changed depending on the air pressure. As higher the tire pressure the grind level should set to minus more. When grinding cross-country ski the distance between the feed roller - grinding stone should be decreased to ensure the adhesion at the ski tip and the ski end.

- Enter the desired distance feed roller - grinding stone. The input value is between -3 and +3 mm.

Offset start level

- With this option the point can be changed as of which the feeding arm with active power regulation starts to lower itself slowly.

Generator power

- If a generator is used this function must be activated.

! If the machine is powered by a generator and this function has not been activated, the generator can be heavily damaged. Therefore activate the function before switching the machine off and disconnecting it from the power network! If the activation of the function was forgotten, it is imperative that it is still be done before the first movement of the grinding stone. Backfeeding can damage the generator.

i When leaving by pressing the button " " changes are assumed. When switching on the machine for the next time, they are set back to the previous values. Press the button „Save“ to overtake the settings after the next switch on.

Screensaver

By activating this function the screensaver is switched on, when there was no action on the touch screen for more than 10 minutes.

- Press the button " " to change to the window „MENU“.

9.2 Stone- / diamond changing assistant

[\(see chapt. 11.2 Stone- /diamond changing with the assistant, page 61\)](#)

9.3 Display / Info / IP-Host

- By pressing the button "Display / Info / IP-Host" the following window is opened.



9.3.1 Change date/time

- Touch the field which should be changed.
- Enter the desired number with the number block and confirm with "ENTER".

9.3.2 Change brightness

- The brightness of the screen can be adjusted by pressing the +/- buttons.

9.3.3 Select the language

- The whole menu-driven application is set to the desired language by touching the respective language.

9.3.4 Calibrate touch

- By pressing the button „Calibrate touch“ the calibration routine for the touch starts. When the calibration is called up, it has to be finish and cannot be canceled. Touch the crosslines, which occur on the display one after the other with a pen.

9.4 Times and counters



- By pressing the button „Times and counters“ the following window is opened.

Operating hours

This field shows the total operating hours of the stone aggregate.

Dressing cycles

This field shows the number of dressing cycle since commissioning of the machine.

Grinded ski

This field shows the number of grinded ski since commissioning of the machine.

9.5 Balancing mode

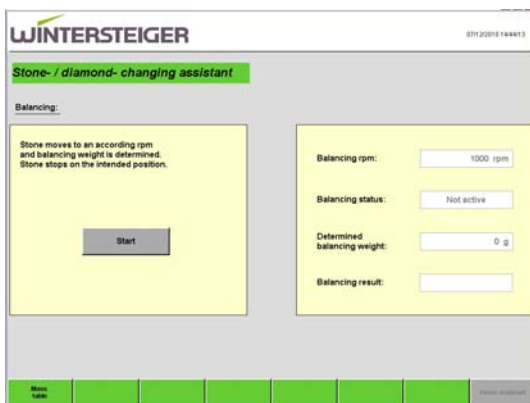

- By pressing the button „Balancing mode“ the balancing mode as described in chapter stone-/diamond changing assistant ([see chapt. 11.2.7 Balancing the grinding stone, page 68](#)).
- Additionally the function „Dry clean (long)“ can be called up directly in the balancing mode. With a not dried stone the balancing result can be falsified.

9.6 Grind-in mode

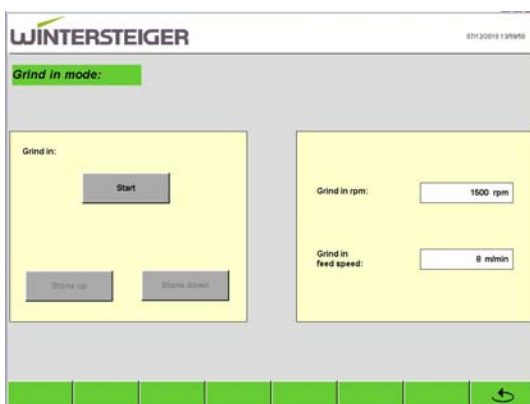

The gummed feed roller has to be grinded even when it is strong worn. Before grinding in we recommend to dress a rough structure to the grinding stone.



Grinding in the feed roller is only possible when the wide grinding stone is mounted.

- Press the button „Grind-in mode“.
- The machine starts, the coolant supply is switched off and the feed roller is lowered.
- The grind-in dressing rpm and grind-in speed can be changed if needed.
 - By pressing the button „Stone up“ the grinding stone moves to the feed roller. Grind in the feed roller till it is even.
 - By pressing the button „Stone down“ the grinding stone moves away from the feed roller.

9.10 Neutral position

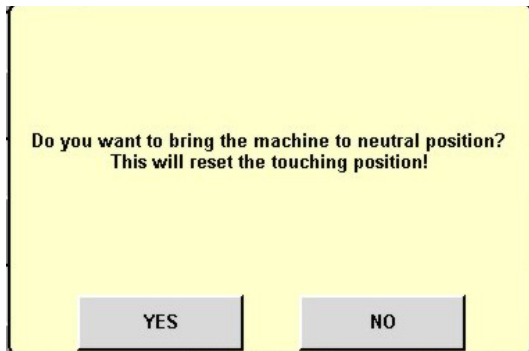

When transporting the machine and after end of season the dressing diamond should be moved to the neutral position to avoid damage of the diamond or the latex cover for the dressing unit.

- Press the button „Neutral position“.
- By pressing „YES“ the dressing diamond is moved to the neutral position.



When switching on the machine for the next time you are asked touching the diamond.

- Press the "  " button to return to the „MENU“.

10 Malfunctions

10.1 Alarm messages on the display

If an error occurs, in the first line of the display one alarm message is shown. By pressing on the alarm line the alarm window is opened. When the error is eliminated, the message expires.



Risk of injury!

Work on the machine's electrical system must be carried out by a qualified electrician in line with accepted practices!

On-screen messages and error number	Cause	Solution
Battery discharged: 711118	Battery (nearly) exhausted	Replace battery (see chapt. 11.4 Changing the battery on the operating terminal, page 70)
Emergency stop pressed: 666667	Emergency stop button at control panel pressed, or button or cable defective	Release the emergency stop button. If this error reoccurs, please contact WINTERSTEIGER customer service.
Stone coverage removed: 666666	Stone coverage was removed	Mount stone coverage
Stone cleaner worn: 666669	Stone cleaner is worn	see chapt. 11.3 Changing the stone cleaning block, page 70
Invalid stone diameter: 700000	Stone diameter was not detected: Laser soiled Laser defective	Clean laser Change laser
Further errors can only be solved by the customer service.		Please contact WINTERSTEIGER customer service.

10.2 Mechanical malfunctions



Risk of injury!

Work on the machine's electrical system must be carried out by a qualified electrician in line with accepted practices!

Error, malfunction	Cause	Solution
Stone grinding quality not in order		
Vibrations on the grinding stone resp. chatter marks left after stone grinding	The grinding stone is unbalanced. The grinding stone is loosely. The grinding stone is stuck	Balance the stone Tighten and balance Dress the stone once or twice and check the spraying.

Error, malfunction	Cause	Solution
	The grinding stone was sprayed with coolant when standing still.	When cleaning the machine with the cleaning hose close the ball valve for the stone. After cleaning the machine dry-clean the stone.
Grinding stone conglutinates quickly	Pump rpm too low The high pressure pump provides too little pressure Filter cartridge blocked	Increase the pump rpm (see chapt. 9.1 User settings, page 50) Check coolant level Clean: - the sieve of the high pressure pump - the high pressure nozzle Clean the filter cartridge (see chapt. 11.1.4 Cleaning the filter cartridge, page 60)
Base is stringy or burnt	Stone rpm too high insufficient coolant supply	Decrease the grinding rpm Check the coolant level in the tank, check the pipes and spray nozzles, renew the filter fleece Change coolant
Splitting of ski base visible	Feed depth of the diamond too high Vibrations on the grinding stone	Reduce feed depth Face the stone for several times Clean the stone with the stone cleaner Balance the stone
Demolition of stone structure on account of edges.	Contact pressure too high	Decrease contact pressure
Grinding stone not cleaned by dressing.	The dressing diamond is worn out	Mount a new dressing diamond.
Structure not visible	Dressing diamond with too broad needles in use	Use dressing diamond with smaller needles
Ski is ground on one side resp. Structure is non-uniform over the ski width	Centering and V-rollers dirty The gummed feed roller is not parallel (very worn) Diamond diameter too small (diamond is worn too much when dressing)	Clean the rollers Grind in the gummed feed roller Use dressing diamond with higher diamond diameter
Ski does not run through straightly	Input pan resp. output pan is not fixed correct. Centerings are not parallel to each other.	Check the fixation of the input pan resp. output pan. Set the centerings parallel to each other.
Spraying does not run or runs sporadic	Nozzles are blocked. Too few coolant in the container. Pump is blocked.	Clean the nozzles with compressed air. Refill coolant. Dismantle the pump, clean the pump and mantle in the same order, than it was dismantled.

11 Maintenance



Risk of injury!

Observe safety instructions for maintenance work and repairs ([see chapt. 2.2 Safety information, page 7](#)).

11.1 Maintenance table

Pos. Nr.	Maintenance work	daily	weekly	monthly	yearly	Comment
Cleaning						
1) ¹	Entire exterior of machine and interior in particular	x	-	-	-	see chapt. 11.1.2 Cleaning the machine with the cleaning hose, page 59
2)	Display touch surface	x	-	-	-	When the machine is switched off with a damp cloth
3)	Clean support rollers and V-rollers	x	-	-	-	Deposits of dirt on rollers have a negative effect on grinding.
4)	Cleaning laser	x	-	-	-	see chapt. 11.1.3 Cleaning the laser, page 60
5)	Cleaning feed roller	x	-	-	-	
Coolant system						
6)	Check coolant level	x	-	-	-	see chapt. 4.4.2 Coolant container, page 24
7)	Clean the filter sock			-		Change if necessary
8)	Change the filter fleece	x	-	-	-	see chapt. 4.4.2 Coolant container, page 24
9)	Clean filter mat	x	-	-	-	Change if necessary
10)	Readjust the stone spraying and the safety sheet of the splash guard	-	x	-	-	see chapt. 11.2.3 Changing the grinding stone, page 64
11)	Clean the filter cartridge	x	-	-	-	When the pressure difference in operation is higher than 1 bar between the manometer pump and manometer fine filter, clean the filter cartridge (see chapt. 11.1.4 Cleaning the filter cartridge, page 60).
12)	Clean the magnetic stick	x	-	-	-	Remove the magnetic stick from the coolant container and clean it with a cloth (more often if necessary)
13)	Check PH-value and mixture ratio	-	x	-	-	Appropriate measuring instruments available as accessories
14)	Change coolant	-	-	x	-	(see chapt. 2.2.2 General safety information, page 8) Mixing ratio: see indications of tank
Other						

Pos. Nr.	Maintenance work	daily	weekly	monthly	yearly	Comment
15)	Check the pressure in the latex cover at the dressing unit	x	-	-	-	Visual check - the latex cover must have a tight bow.
16)	Maintenance by WINTERSTEIGER customer service department	-	-	-	x	Wear is unavoidable. Proper maintenance and checks are preventative measures and safeguard against breakdown and subsequent damage.

1 **Danger of corrosion: Do not use tap water to clean the machine! For cleaning, always use the cleaning hose and the coolant!**
 Cleaning of the machine with a high pressure cleaner is not permitted! No liability or warranty will be assumed for consequential damages if the above is not observed.

11.1.1 Maintenance after end of season

The following should be executed after the end of season:

- All the work listed in the table "Maintenance work".
- Drain coolant system and clean.
- Preserve all machine parts.
- Move the dressing diamond to the neutral position ([see chapt. 9.10 Neutral position, page 55](#)).

11.1.2 Cleaning the machine with the cleaning hose



Danger of corrosion! To avoid corrosion, always use the cleaning hose and the coolant when cleaning the machine!

The following points must be observed when cleaning the unit with the cleaning hose:

- Main switch must be switched on.
- Press start button resp. the emergency stop button when the machine is switched on.
- Press button „Start cleaning mode“ on the start display.

The following message points out that

- the ball valve of the coolant supply has to be closed ([see chapt. 4.4.2 Coolant container, page 24](#)).
- the cleaning mode has to be finished so that the stone is dry-cleaned after cleaning.
- After confirming the message, the cleaning pump is switched on.
- Clean the machine.
- When pressing the button „Start cleaning mode“ again, the cleaning pump is switched off.

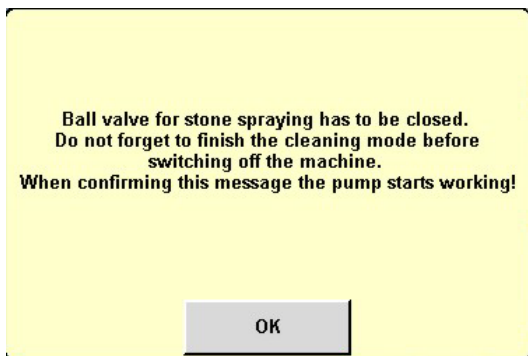

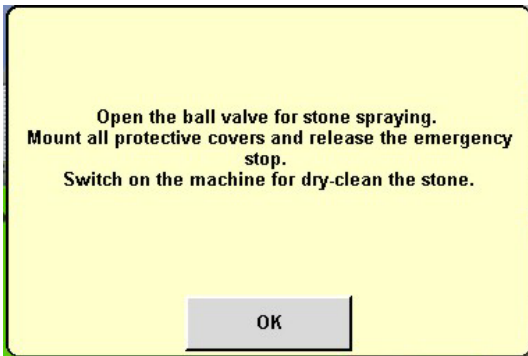

The following message points out that

- the ball valve for the coolant supply has to be opened
- the machine has to be switched on, to activate the automatic dry-clean of the stone (otherwise danger of unbalance)

11.1.3 Cleaning the laser

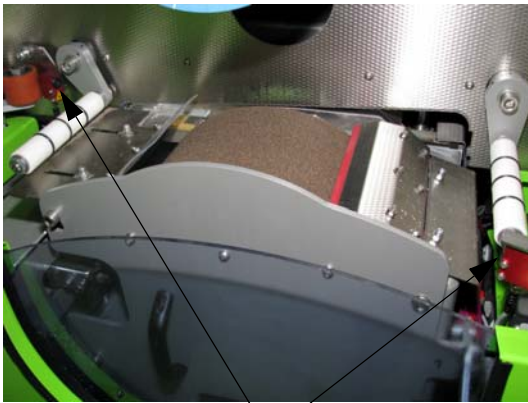

1



To ensure an optimal stone measurement, clean the laser daily.



Do not spray the laser with the cleaning hose!

- Press emergency stop button
- Clean the laser glass [1] with a smooth cloth free of streaks.



Risk of eye injuries!

Attention - do not look into the laser!

11.1.4 Cleaning the filter cartridge



2

3

When the pressure difference in operation is higher than 1 bar between the manometer pump [2] and manometer fine filter [3], clean the filter cartridge.

- Press emergency stop button
- Remove the filter glass and clean the filter cartridge with clear water.

11.2 Stone- /diamond changing with the assistant



The stone- /diamond changing assistant has to be proceeded at every change of the stone resp. diamond. Otherwise a collision of the diamond with the grinding stone may occur!



- Press the button „MENU“ on the editing display.

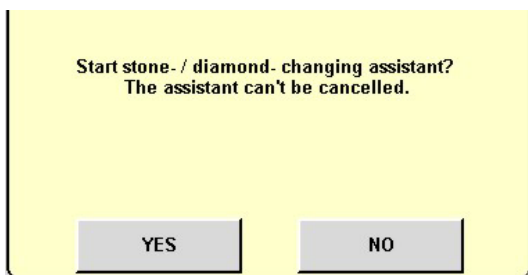

By pressing the button „Stone- /diamond changing assistant“ in the menu, the assistant, which will explain the procedure step by step, is started.



As soon as confirmed with „YES“ the changing assistant has to be carried through to avoid damage of the machine.

- Press button „YES“

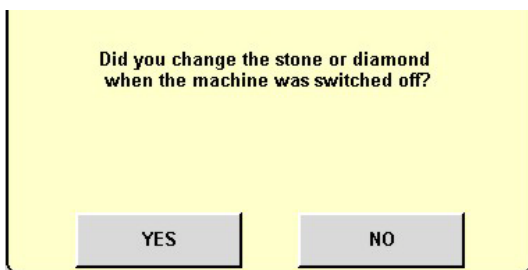

- If the grinding stone or the diamond was changed, while the machine was switched off, press „YES“. The following message is skipped.
- Press button „NO“ if the grinding stone or the diamond still have to be changed.

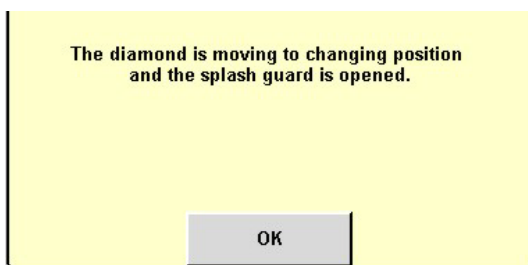

When the last message was confirmed with „NO“, the diamond moves to the changing position and the splash guard is opened.

- Confirm message with „OK“.

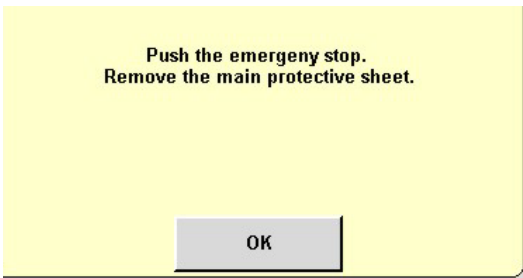

- Press the emergency stop button.



Do not switch off the main switch!

- Remove the main protective sheet ([see chapt. 2.5 Safety devices, page 12](#))

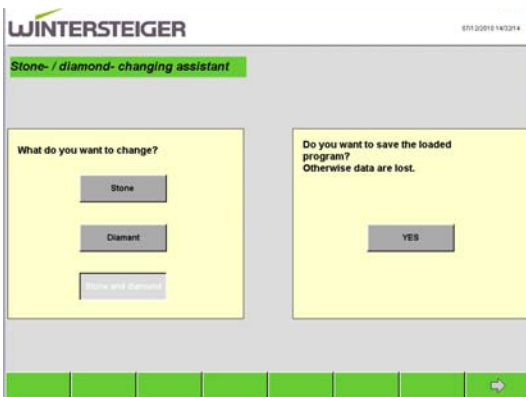

When the active grinding program was changed but not saved, before starting the changing assistant there is the opportunity to save changes, otherwise they will be lost.

- If necessary save the grinding program by pressing the button „YES“.
- Press the respective button to choose the tool, which should be changed.
- e.g. press button „Stone and diamond“.
- Press button "".

11.2.1 Changing the dressing diamond

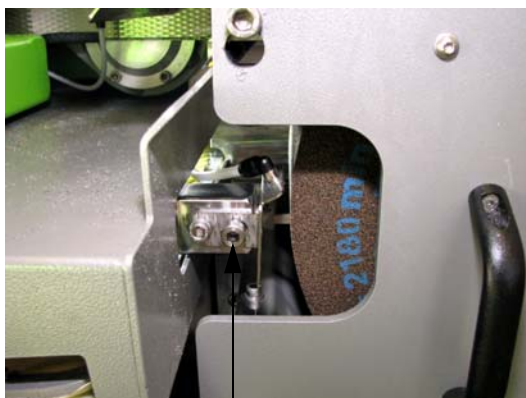
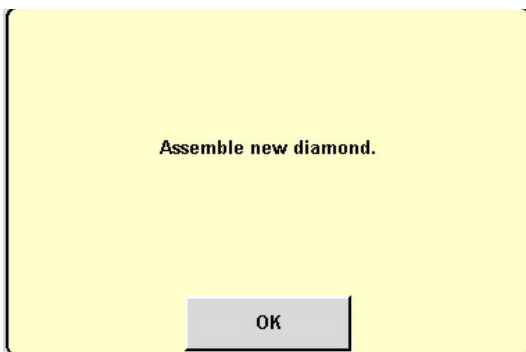

- Loosen hexagon socket screw [1], remove dressing diamond and clean borehole. Install and tighten new diamond with well lubricated shaft up to the limit stop.



The hexagon socket screw must be pressed against end face of diamond shaft.

- Confirm the diamond change with the button „OK“.

1

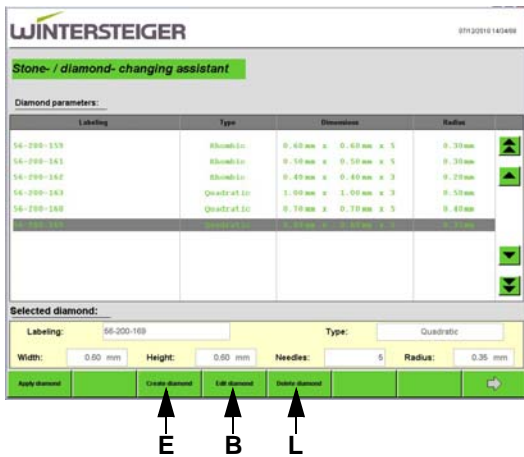

- The diamond type that is used must be selected in order to attain agreement between the structure preview and the actual grinding pattern on the ski.
- Select the diamond from the list and confirm with the button „Take diamond“. If the diamond is not available in the list, please add it ([see chapt. 11.2.2 Adding - modifying - deleting a diamond, page 63](#)).
- Press button "  ".

11.2.2 Adding - modifying - deleting a diamond



- Press the button „Create diamond“ [E] to add a new diamond.
- Enter the data of the new diamond into the input value.
- By pressing the button „Save“ the new diamond is assumed into the diamond list.

New added diamonds are shown in black color in the list.

- For editing the data press button „Edit diamond“ [B].
- For deleting a diamond press button „Delete diamond“ [L].

 **Only diamonds which are shown in black color in the list can be edited and deleted.**

11.2.3 Changing the grinding stone

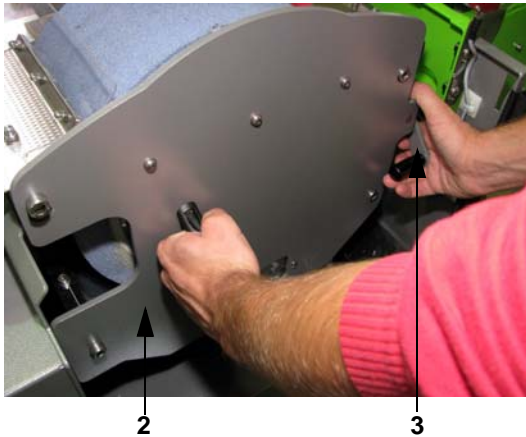

- Remove the stone coverage [2] by loosening the lever [3] and lifting the stone coverage.
- Confirm removing the stone coverage with button „OK“.



If a grinding stone from Micro NC is mounted, the grinding stone has to be dismantled including the flange. Otherwise dismantle the grinding stone as per following description.

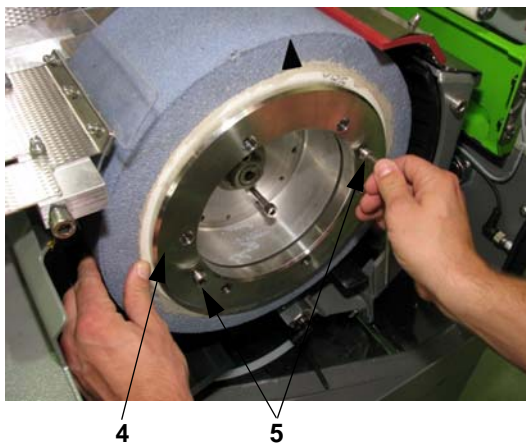

- Remove 6 Allen screws from the tighten ring [4].
- To remove the tighten ring screw in 2 Allen screws into the threads.

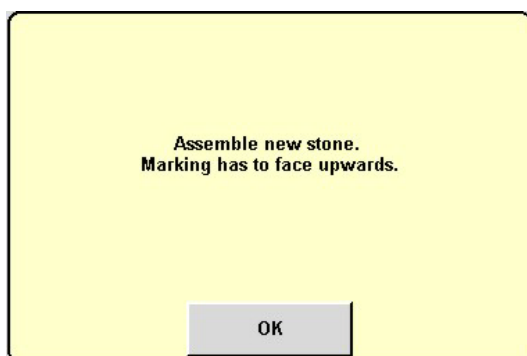



6

- After removing the tighten ring, remove the grinding stone.
- Clean stone retainer [6] and tighten ring [4]



Check the new grinding stone categorical for damages from transport.

- Set the safety sheet of the splash guard [8] back.
- Put the new grinding stone onto the stone retainer.



Mount the grinding stone in a way that the mark with the unbalancing information faces upwards.

- Fix the grinding stone with the tighten ring and the 6 Allen screws.



When tightening the tighten ring take care, that first the screws are tightened fingertight to that the tension ring can center. Afterwards fasten the screws crosswise.

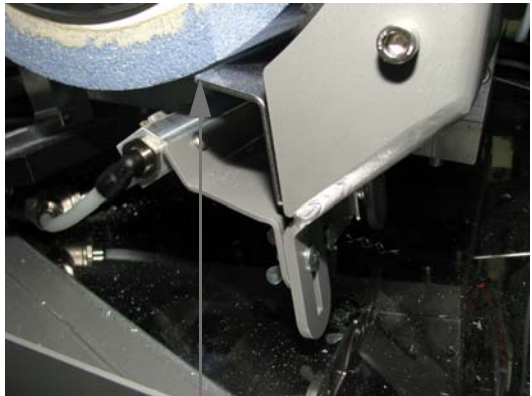

7

- Move the stone spraying to the stone (Distance between splash guard [7] and grinding stone about 1 Millimeter).

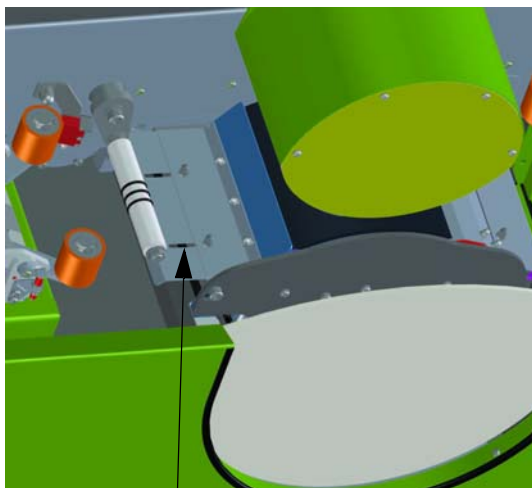

8

- Set the safety sheet of the splash guard [8] so that the splash guard has a distance of 3 mm to the grinding stone.



- Confirm the mounting of the stone with button „OK“.
- Select the stone from the list and confirm with the button „Take stone“. If the diamond is not available in the list, please add it ([see chapt. 11.2.4 Add grinding stone, page 66](#)).

i Take care for flange type - Race NC or Micro NC!

- Press button " ".

11.2.4 Add grinding stone



- Press the button „Create stone“ [E] to add a new grinding stone.
- Enter the data of the new grinding stone into the input value.
- By pressing the button „Save“ the new grinding stone is assumed into the grinding stone list.

New added grinding stones are shown in black color in the list.

- For editing the data press button „Edit stone“ [B].
- For deleting a grinding stone press button „Delete stone“ [L].

i Only grinding stones which are shown in black color in the list can be edited and deleted.

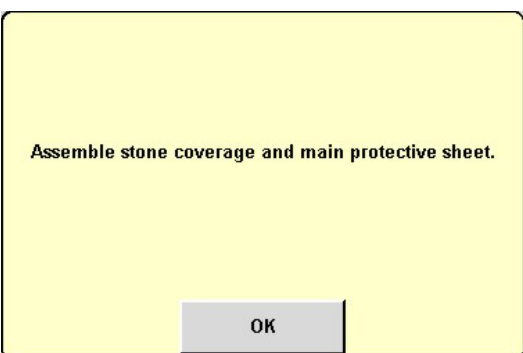

- Mount the stone coverage [2] and fix with lever [3].
- Mount the main protective guard.
- Confirm mounting with button „OK“.

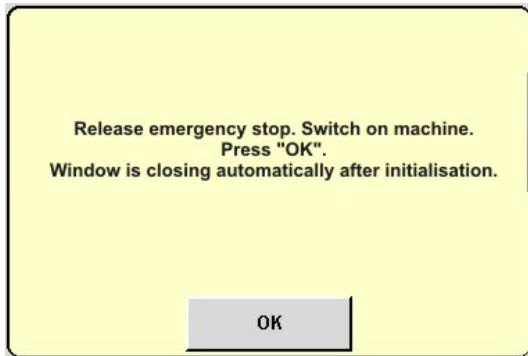

- Loosen the emergency stop button.
- By pressing the start button on the operating panel the machine is initialized.
- Press button „OK“.

11.2.5 Touching the diamond to the grinding stone

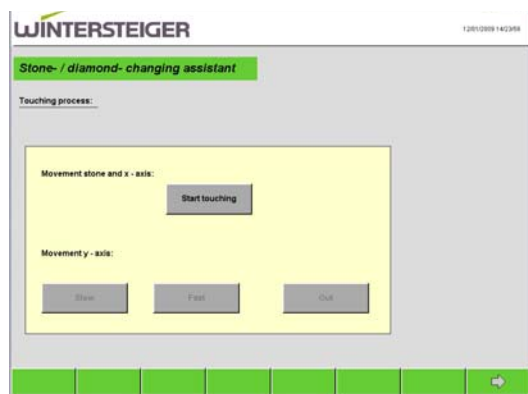

- By pressing the button „Start touching“ the grinding stone speeds up and the dressing diamond oscillates.

i When the touching process is started, it has to be finished correctly, otherwise errors would occur.

- Press the button „Fast“ until the dressing diamond is in a short distance to the grinding stone. Then press the button „Slow“ until the dressing diamond has slight contact to the grinding stone.
- By pressing the button „Out“ the dressing diamond moves back.



If a grinding stone with the right structure is assembled, the touching process can be skipped.

i When the touching process is skipped the touching position is reset. The diamond doesn't move from the current position. Before the next facing or dressing process the diamond has to be touched to the grinding stone.

- After touching the dressing diamond press the button "  ".

11.2.6 Facing the grinding stone

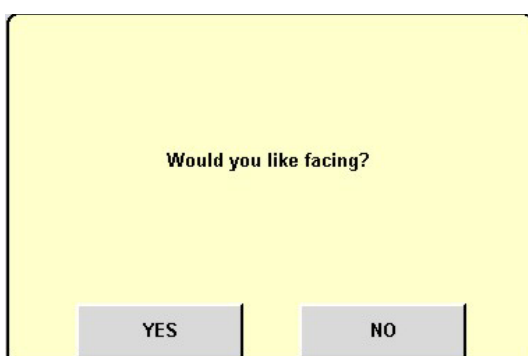

After changing the grinding stone, it is necessary to face it.

- Press button „YES“.

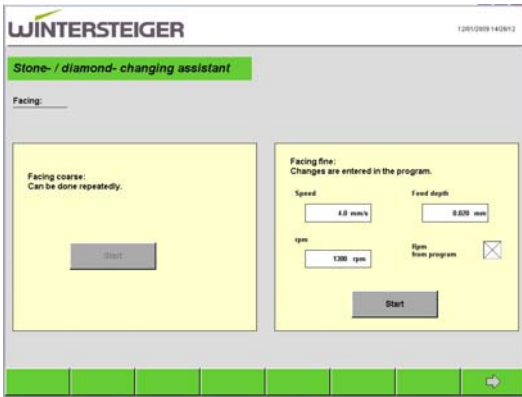

To ensure an even grinding stone run the facing coarse twice or thrice.
After facing coarse run the facing fine.

When facing fine the facing parameters are use [\(see chapt. 7.1.8 Facing parameters, page 44\)](#). They however can be changed in this window.

i Facing fine cannot be repeated. Process facing coarse for a several time so get an even grinding stone.

- After facing press the button "".

i If only the change of the diamond was chosen, the assistant is finished after facing the grinding stone.

11.2.7 Balancing the grinding stone

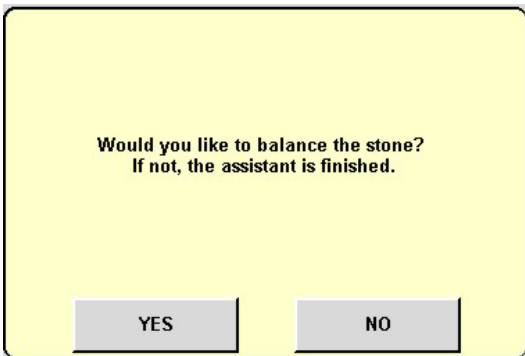

To get a precise structure the grinding stone has to be balanced after mounting and facing.

- Press button „YES“.

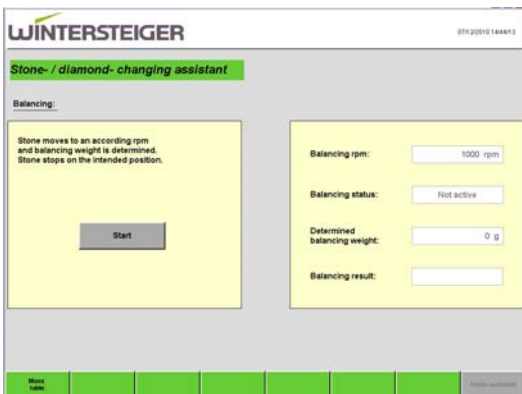

- Press the button „Start“ to start the balancing process.

When the balancing process is finished, the determined balancing weight is shown.

- Press button „Mass table“.



In the mass table the available balancing weights are shown.

- Press the emergency stop button.
- Remove the main protective sheet and the stone covering.

i Do not sophisticate the grinding stone when removing the covers, because the balancing weights (screws) have to be screwed in into the lowestest position of the stone flange.



8

- Screw in into the lowestest position [8] a screw eventually with washer with the determined balancing weight.

i When the balancing stone stops in a position where no borehole is, split the balancing weight to the nearest boreholes left and right.

	Weight (gram)
Allen screw M8x16	12 g
Allen screw M8x20	13 g
Allen screw M8x25	15 g
Allen screw M8x30	16 g
Allen screw M8x35	18 g
Washer A8	8 g

- Mount the stone coverage and the main protective sheet
- Loosen the emergency stop button.
- Press the „Start“ button to run the balancing process.

If the determined balancing weight is under 10 gram the grinding stone is balanced enough, if not, repeat the balancing.

Balancing results

- less than 10 g - Result „very good“. The grinding stone is optimal balanced.
- less than 15 g - Result „good“, add eventually balancing weights and repeat the balancing process.
- more than 15 g - Result „bad“, add eventually balancing weights and repeat the balancing process.
- After balancing press the button „Finish assistant“.

11.2.8 Carry out test run according to official regulations



A test must be performed for every grinding device with an outer diameter of more than 100 mm (3.94 in) before being used for the first time and after every retightening. This test shall be conducted with no load, at the highest allowable peripheral speed and in the presence of an expert. All grinding machines must be run for at least one minute. The test run may be performed only after all protective devices have been mounted and no one is standing in the danger zone. The grinding device may be used only after a flawless test run.

11.3 Changing the stone cleaning block



1

When the message „stone cleaner worn“ is shown in the error message line of the operating panel, the stone cleaning block has to be changed. From that time the stone cleaning function is disabled until the change.

- Switch off the main switch.
- Remove main protective sheet.
- Remove stone coverage.
- Remove the worn stone cleaning block by loosening the both screws [1].
- Mount the new stone cleaning block with the metal strip inwards.



Remove the fallen out metal strip from the worn stone cleaning block from the bottom of the pan.

11.4 Changing the battery on the operating terminal

If an error message of "Battery discharged" is shown at the control panel, you must replace the SPC control unit battery within three weeks.

The life of the battery is about 2 years under normal circumstances, however, higher temperatures can impact battery life.



Always have a spare battery available.
If the battery is not changed in time all the set values may be lost.



Change the battery as follows:



If you have not switched on the power supply, switch it on and leave it on for at least a minute and then switch it off again.

- Switch off the master switch.
- Open the operating panel with a two-way key and rotate it forward.

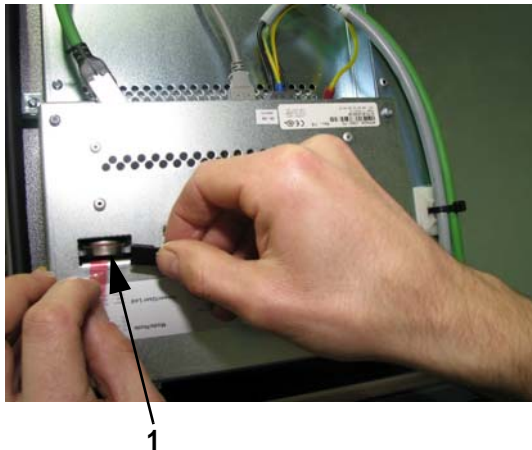

- Remove the battery cover.
- Pull the red lug to remove the battery [1] and immediately insert a new battery (order number 15-480-106).



The battery must be replaced within 10 minutes to prevent PLC data being lost. Do not touch battery with pliers or tweezers --> short circuit! Only the faces of the battery can be touched by hand.



Lithium batteries are hazardous waste! Dispose of empty batteries in line with local waste disposal regulations.

11.5 General information for the correct handling of solid cooling lubricants

The solid cooling lubricants contain a high number of different chemicals so that they can fulfill their tasks (cooling, lubrication, removal of chippings, corrosion prevention). This makes the maintenance and care of the solid cooling lubricants very important.

Organizational measures



Please take special care of the cleanliness of the solid cooling lubricant emulsion to prevent the development of nitrosamines and microbial growth!

Among others, please adhere to the following measures:

- Prevent the presence of organic and anorganic food, cigarette butts, corrosion protection materials, etc.
- Avoid the invasion of foreign oils into the solid cooling lubricant systems.
- Avoid the intrusion of impurities and contaminants, which contain secondary amines or which release those in significant quantities (above 0.2% in solid cooling lubricant concentrate). This includes detergents, certain corrosion protection materials, system cleaners.
- The following analyses and measurements must be performed. The TRGS 611 is the legal basis for the listed limit values in Austria and Germany. The limit values in other countries must be applied in accordance with the local laws.

Tests	Measurement frequencies	Limit value
KSS concentration	weekly	according to manufacturer's information
Nitrate content of the preparation water	from time to time	max. 50 mg/l
pH value	weekly	8.5 - 9.0
Nitrite	weekly	max. 20 mg/l
Microbial count (recommended)	monthly	10 ⁶ germs
Total hardness	as required	app. 16°d

As part of the FLUIDMANAGEMENT, WINTERSTEIGER offers an analysis case for monitoring and measuring solid cooling lubricants as well as the documentation of the measurement results. This allows you to immediately implement counteractive measures if the limit values are exceeded and you can extend the frequencies for the coolant change significantly beyond the 4 weeks. In addition, the WINTERSTEIGER-Fluidmanagement includes accessories (high performance lubrication spray, system cleaner, machine foam cleaner, preservatives, skin protection sets), which are adapted to the emulsion and therefore largely prevent the introduction of contaminants.

Immediately implement counteractive measures or change the grinding coolant if the limit values are exceeded. **The emulsion must be changed after app. 1,000 pairs of skis or after 4 weeks at the latest if WINTERSTEIGER-Fluidmanagement is not used.** Drain the coolant system and clean it with a system cleaner after the end of the season and during longer standstills of the machine.

Safety measures

Appropriate protective clothing (e.g. protective gloves, protective goggles, fluid repellent protective clothing) should be used because the solid cooling lubricants have, among others, a skin irritation effect. A preventive skin protection (barrier cream) should be used if skin contact cannot be avoided.

Disposal

Do not drain into the sewage water system! Adequate disposal is required in accordance with the manufacturer's safety data sheet information and with the local laws.

12 Shut-down and disposal



Risk of injury!

Disconnect the machine from the mains supply or any external drive prior to shutting down and dismantling. Use only suitable tools for dismantling.



When shutting down the machine dismantle and dispose of all machine parts properly. Clean all oily and greasy components prior to disposal.

Oil and grease should never be allowed to pollute the environment.

Ensure that all disposal regulations specific to your country are adhered to!

- Dismantle the machine properly into its individual components.
- Clean oily and greasy components.
- Dispose of components by material group (steel, plastic, electrical and electronic components, etc.).
- Dispose of oil and grease in an environmentally friendly manner.

CE **Konformitätserklärung**
Declaration of Conformity
Certificat de conformité
Declaración de conformidad
Dichiarazione di conformità



Hiermit erklären wir, dass das Produkt:

We hereby declare that this product...

Par la présente nous certifions que le dit produit:

Por la presente declaramos que el producto:

Con la presente dichiariamo che il prodotto:

Race NC

No.:

Steinschleifmaschine

Stone grinder

folgender(-en) einschlägigen Bestimmung(en) entspricht

conforms to the following regulations:

correspond à la (aux) spécification(s) suivante(s)

corresponde a la(s) siguiente(s) directiva(s) competente(s)

è conforme alla(e) seguente(i) disposizione(i)

EG-Maschinenrichtlinie 2006/42/EG

EG-Niederspannungsrichtlinie 2006/95/EG

EG-EMV-Richtlinie 2004/108/EG

Dokumentations-Bevollmächtigter:

Person authorised to compile the technical file:

Personne autorisée à constituer le dossier technique:

Persona facultada para elaborar el expediente técnico:

Persona autorizzata a costituire il fascicolo tecnico:

Mag. Gottfried Aschauer

WINTERSTEIGER AG

A-4910 Ried / I., Dimmelstraße 9

Ried /I.,am 13.01.2010



Ing. Walter Aumayr
Vorstand



Mag. Gottfried Aschauer
CE-Beauftragter